

House Type Approval Certificate

Certificate No: **STAS/23/056/DM105AMD/01**
 Date: **20 March 2024**

A	Certificate Holder:	
	BDW Trading Ltd (Barratt Homes) 7 Buchanan gate, Cumbernauld Road, Stepps, Glasgow, G33 6FB E-mail: michael.mclean@barratthomes.co.uk Tel: 0141 779 8300	

B	House Type Titles:	
	Description:	2022 Regulations Rossdhu – 2 storey, 3 bedroom mid/end terraced

C	The domestic type approval has been assessed on the following drawings and specifications:	
	See attached annexe to this certificate	

D	Climatic conditions: The design may be built in areas where the climatic conditions are equal to or less than those detailed below:		
	Wind: (as defined in BS 6399-2)	Standard effective wind speed, $V_e =$ For maximum effective height = Has funnelling been considered?	29.6 m/s 8.15m No
	Wind: (as defined in CP3: ChapterV)	Design wind speed, $V_s =$ (relevant to the building frame, at a height of 3m or less)	44.4m/s
	Snow: (as defined in BS 6399-3)	Site snow load, $S_o =$ Influenced by adjacent buildings?	0.6 kN/m2 No
	Resistance to moisture/durability of exposed elements:	Max exposure (to wind driven rain) grading, as defined in BRE Report – Thermal Insulation: Avoiding Risks, Second Edition, 1994, to be exposurezone: Exposure to sea spray (i.e., coastal region) or de-icing salts? Other air contaminants or biological factors – please specify any enhanced resistance if applicable (refer to BS7543 for guidance)	Zone 4 Yes None
	Design Life: (per BS 7543 – Durability of buildings and building elements, products and components)	Category of building design life = Design life of primary building envelope	60 years 60 years

E	Conditions of certification:	
	1.	The design shown and the specifications and materials referred to have been assessed and approved in accordance with the Building (Scotland) Regulations 2004 and in accordance with the supporting guidance in the Domestic Technical Handbooks which came into force with effect from 1 June 2022.
	2.	The certificate shall be valid until invalidated by formal notice by the Local Authority Building Standards Scotland
	3.	The design shown and the materials specified shall not be changed without reference to the Local Authority Building Standards Scotland responsible for certifying the system.
	4.	Where reference is made on a plan or specification document to any Code of Practice, British or European Standard or manufacturer's instruction it shall be construed as a reference to such publication in the form in which it is in force at the material time at the point of construction.
	5.	This certificate should not be regarded as a formal approval under the building warrant process prescribed by the Building (Scotland) Act 2003 enacted from 1 May 2005
	6.	The Bayne Stevenson Associates Statement of Structural Adequacy referenced here under Section G dated March 2024, confirm that a structural appraisal has been carried out. It confirms that further site-specific information MUST BE made available when a site-specific building warrant is sought. Such additional information should take cognisance of Procedural Guidance on Certification including information to be submitted with a Building Warrant Application dated April 2010 Version 2 (January 2017). Confirmation of a holistic approach to structural adequacy of the <u>entire completed building</u> shall be provided by a registered engineer to the local authority within whose area the site-specific dwelling is to be built.
	7.	This certificate confirms compliance with Mandatory Standard 6.1, based on example criteria with regards to orientation, shading, sheltering and resultant PV array efficiency. Site specific information will be required to confirm the actual DER for the STAS approved house type on each plot on a particular site.

Annexe of drawings, certificates and specification documents used in the assessment:

F	Drawing Number:	Description:	Rev
	2020/STAS/DATA	Data Sheet	4
	2020/STAS/01	Planning Layout	A
	2020/STAS/02	Elevations	A
	2020/STAS/03	Ground Floor Layout	B
	2020/STAS/04	First Floor Layout	C
	2020/STAS/05	Foundation Layout	A
	2020/STAS/06	Roof Layout	A
	2020/STAS/07	Section A-A	A
	2020/STAS/08	Kitchen Layout	-
	2020/STAS/09	Future Shower Room Layout	-
	2020/STAS/10	Joist Layout	-
	B-STAS (ROSSDHU-SA03-END-SG)TP	TEMPLATE LAYOUT	A
	B-STAS (ROSSDHU-SA03-SEMI-SG)01	BLOCK WALLPLATE & SOLEPLATE SETTING OUT LAYOUT	A
	B-STAS (ROSSDHU-SA03-SEMI-SG)02	BLOCK ROOF TRUSS LAYOUT & PROFILES	A
	140267/ROSSDHU/001	Timber Frame Appraisal Sheet 1	-
	140267/ROSSDHU/002	Timber Frame Appraisal Sheet 2	-
	Eco2Solar ROSSDHU PV DESIGNS	Rossdhu PV Designs	

G	Certification	
	Statement of structural adequacy	Bayne Stevenson Associates dated March 2024

H	Specifications	
	Bayne Stevenson Associates	Structural calculations
	Barratt North Scotland Timber Frame 2022	Specification 25.10.23
	Summary of variations	Information document

I	Authority:
	This system type approval certificate consisting of 2 pages is authorised by Scottish Building Standards Hub on behalf on behalf of the Local Authority Building Standards Scotland (LABSS).

Affordable STAS – Summary of updates

This application is to revise the STAS approved Affordable Range made up of 8 house types;

- Ardlui & Ardvorlich - STAS/20/056/DM105/06
- Cailness & Cameron - STAS/20/056/DM105/03
- Cashell & Endrick - STAS/20/056/DM105/07
- Finlas - STAS/20/056/DM105/02
- Inverbeg - STAS/20/056/DM105/04
- Rossdhu - STAS/20/056/DM105/01
- Shantron – STAS/20/056/DM105/05
- Sloy - STAS/20/056/DM105/08

General revisions

Please see list below of general revisions that have been applied to every house.

- **Tenure blind amendments** – the introduction of front door surrounds and canopies to all house types in order to achieve the same aesthetic as our private houses.
- **Insulation removed from the mid floor** – updated specification sheet has been supplied.
- **Single Service Track** - Gas, Water & Electric services repositioned to come into the house using 1 single service track.

House Type specific revisions

Please see list of house type specific revisions below.

Ardlui & Ardvorlich

- Standardisation of window sizes
- Addition of dimensions
- Changes to electrics
- SVP to tile vent
- Staircase rising increased
- Pitch of roof above hall increased
- Removal of weep vents at front and rear soffit level and side roof rake
- All notes standardised across range
- Correction of drawing title boxes
- Dog leg added to loadbearing wall path
- 89mm racking frame added to loadbearing wall (corrected to tie in with engineering drawings)
- SVP pop-up updated to match GA
- FF Store increased in size
- Wardrobes removed from bedrooms
- Loft hatch location amended
- Section amended to tie in with timber kit drawing
- Weep vents amended to follow standard guidance.

Cailness & Cameron

- Hatching corrected
- Removal of weep vents at front and rear soffit level and side roof rake
- Addition of dimensions
- All notes standardised across range
- Correction of drawing title boxes
- Electrical symbols key updated
- Door schedules revised
- Storey Rod height amended to give more floor to ceiling height in GF Cailness (to match Oregon Timber Frame Designs)
- Layouts amended in line with Oregon TF comments

Cashell & Endrick

- -Hatching corrected
- -Addition of dimensions
- -All notes standardised across range
- -Correction of drawing title boxes
- -Electrical symbols key updated
- -Layouts updated in line with Oregon TF comments
- - wall adjusted to create space for kitchen layout
- - Stairwell opening reviewed (to tie in with TF drawings)
- - Section updated in line with Oregon TF comments

Finlas

- Addition of dimensions
- All notes standardised across range
- Standardisation of window sizes
- Correction of drawing title boxes
- Hatching corrected
- layout amended to reflect Timber Frame layout

Inverbeg

- Hatching corrected
- Removal of weep vents at front and rear soffit level and side roof rake
- Addition of dimensions
- All notes standardised across range
- Correction of drawing title boxes
- Electrical symbols key updated
- Canopy overhang increased
- Water and BT inlets shown on underbuilds
- Extract and FAI runs revised
- 9mm OSB added to load bearing wall
- Bulkhead at stair revised at stair
- Window schedules rationalised

Rosdhu

- Bath in bathroom rotated 180 degrees and shelf changed into full height bulk head
- Front door position revised to match TK Designs
- Addition of dimensions
- All notes standardised across range
- Correction of drawing title boxes
- Bathroom shower arrangement revised
- First Floor Bathroom layout revised
- 9mm OSB added to loadbearing wall to match TK Designs
- Stairwell opening set at standard 1050mm wide to match TK Designs

Shantron

- Addition of dimensions
- All notes standardised across range
- Correction of drawing title boxes
- Venting to soffit added on roof plan
- 9mm OSB added to Load bearing wall to match TK designs
- Bulkhead at stair revised to match TK designs
- Stairwell revised to suit stairwell protection system
- Door and window schedule corrected.

Sloy

- Addition of dimensions
- All notes standardised across range
- Correction of drawing title boxes
- Escape notes added to FF windows
- Electrical symbols key updated
- Rearrangement of kitchen layout
- Gable window amended to be 1050mm in height to reflect TK designs
- Lintel spec updated in line with IG drawings

Third Party Changes

Standard Appraisal Notes

Wall Panels

- All external walls to comprise 38x140 (C16) studs at maximum 600mm centres with 9mm osb cladding to cavity side nailed to S550 nailing specification UNO.
- All internal and party walls to comprise 38x89 (C16) studs at maximum 600mm centres with mid-height dwangs and plasterboard cladding UNO. If a wider wall construction is used for party walls adjacent to stairs 38x140 studs to be used.
- The adjacent table summarises all details relevant to wall panel specifications. Top row denotes stud centres, middle row standard racking specification and if shown the bottom row any enhanced site nailing requirements relative to Fairhurst site nailing schedule.
- Typical Racking Specification Notation:
 - SS50: Single Sheathed 9mm osb nailed with min 2.850 nails to studs at 50mm perimeter centres. Osb nailing varies 50mm to 150mm.
 - DS50: Double Sheathed 9mm osb with 2.850 nails to studs at 50mm perimeter centres.
 - PBD: Standard plasterboard clad internal wall panel with mid-height dwangs.
 - SWD: Standard plasterboard clad party wall panels with mid-height dwangs. Walls to be braced in accordance with the requirements of clause 4.7.5 of BS 5268: Section 6.1 with 600mm long 9mm osb to extend from each end of the wall panel.
- Where enhanced racking resistance is required internal walls will be clad with one or two layers of 9mm osb. For housing these walls are shown hatched as
- Stud centres for all external wall panels can be averaged however, internal studs are set at the maximum centres noted.
- Cullen PWS-200 party wall straps to be provided at a minimum 1200mm horizontal centres U.N.O. All straps to be installed in accordance with the Cullen Technical Manual.

Wall Panels (cont'd)

All timber lintels incorporated within the floor zone (upstand) supported on two full height studs U.N.O.	All timber lintels incorporated within the wall panel (downstand) supported on one cripple & one full height stud U.N.O.	Standard timber lintel and beam notation as below with lintels supported on minimum one cripple stud and one full height stud.
S140 38 x 140 C16 S166 45 x 166 C24 S190 45 x 190 C24 S220 44 x 220 C24 S235 38 x 235 C24	S140K 45 x 140 Kerto-S LVL S166K 45 x 166 Kerto-S LVL S190K 45 x 190 Kerto-S LVL S220K 45 x 220 Kerto-S LVL S235K 45 x 235 Kerto-S LVL	D140 2/38 x 140 C16 D166 2/45 x 166 C24 D190 2/45 x 190 C24 D220 2/44 x 220 C24 D235 2/38 x 235 C24
T140 3/38 x 140 C16 T166 3/45 x 166 C24 T190 3/45 x 190 C24 T220 3/44 x 220 C24 T235 3/38 x 235 C24	T140K 3/45 x 140 Kerto-S LVL T166K 3/45 x 166 Kerto-S LVL T190K 3/45 x 190 Kerto-S LVL T220K 3/45 x 220 Kerto-S LVL T235K 3/45 x 235 Kerto-S LVL	

All timber lintels to be hard to the underside of the wall panel top rail with infill below to form the head and cill panels. For larger structural openings head and cill panels to have multiple continuous horizontal rails between the studs based on the spans below:

< 2.0m	- 1No continuous 38x140 rail
< 2.8m	- 2No continuous 38x140 rails
< 3.6m	- 3No continuous 38x140 rails
> 3.6m	- Project specific details required

Site Nailing

- All site nailing to be in accordance with Fairhurst standard site nailing schedule which is generally as follows:
 - 300mm centres for 89mm kit.
 - 200mm centres for 140mm kit.
 - 200mm centres for all internal osb clad walls.
- Soleplates to be fixed to concrete floor slab or blockwork underbuild with SPIT HIT-M 8-60-92V either side of openings and at 900mm centres U.N.O.
- Ground floor holding down straps to be provided at all structural corners and at 2.4m centres between.
- Cullen FT-50 wall ties to be provided at a minimum density of 5.5 ties/m² at ground, first and second floor wall panels to secure any blockwork cladding to the timber frame.
- For medium to high rise timber frame Cullen HMT-50 wall ties to be provided at a minimum density of 7.4 ties/m² at third floor wall panels and above to secure any blockwork cladding to the timber frame.
- In addition to the above minimum densities additional wall ties to be provided at 225mm vertical centres adjacent to openings, corners and all expansion joints.
- Responsibility for ensuring compliance with minimum tie densities rests with the contractor to suit the external cladding which will vary on a project by project basis. Wall tie specification is based on a standard 50mm cavity, if a larger cavity is to be used please advise the timber frame engineer.

Fire

The timber frame specifications noted on the appraisal assumes there are no risks associated with fire during construction to neighboring buildings. If the fire risk assessment, undertaken by the timber frame specialist, notes this is not the case enhancements to the timber frame specification via fire rated materials to be made by the specialist.

Generally upgrades to the timber frame will comprise the use of fire rated wall panel sheathing, i.e. fermacell, and the use of fire rated floor decks and/or joists.

I Joist Floors

- All floor joists to be 220 Dp Steico joists of type and centres noted with a single or double 220 Dp LVL edgebinder. Where joists span parallel with external walls perpendicular sprockets to be provided at 600mm centres between the wall and first joist as standard. All floors to be glued and screwed in accordance with NHBC requirements.
- External Wall Panel Blocking. If single edgebinders are used below 140mm external walls then additional blocking will be required within floor zones to spread the load from studs to wall panels below. The alternative to the additional blocking noted below would be the use of double edgebinders.
 - 2 or 1+1 Studs - Edgebinder + single Steico blocking
 - >2 or >1+1 Studs - Edgebinder + single LVL blocking
 - >5 or >4+1 Studs - Edgebinder + double LVL blocking
 - Key Elements - Edgebinder + double LVL blocking
- Internal Wall Panel Blocking. Single Steico midfloor blocking to be provided in the floor zone over internal load-bearing walls to transfer loads through the floor zone. For multi storey buildings double Steico or LVL blocking will be required as noted on the appraisal key section.
- To account for load concentrations enhanced midfloor blocking to be provided below multiple studs as per the below.
 - 2 or 1+1 Studs - Double Steico blocking
 - 3 or 2+1 Studs - Double Steico blocking
 - >3 or >2+1 Studs - Double LVL blocking
 - Key Elements - Double LVL blocking
- Party Wall Panel Blocking. In addition to floor panel edgebinder party walls to be blocked with solid timbers to suit the wall width. All incoming Steico floor joists to have webs packed with full depth timbers.
- Where multiple joists are specified the adjacent floor joists must be detailed from the centre line of the multiple member. The position of any floor trimmers to suit SVP voids etc. is indicative and should trimmer positions be revised to suit joist setting out etc. the timber frame fabricator must forward floor panel details for review.
- All floor joist hangers to be fully nailed Cullen UH hangers with receiving joist (if not solid) to have web packers fitted as standard.
- All multiple member hangers to be fully nailed Cullen UH hangers with receiving joist (if not solid) to have web packers fitted as standard. Where higher loads require to be transferred enhanced hangers to be used as below:
 - Medium Capacity - Cullen HUH hanger with all nail holes filled
 - High Capacity - Cullen MH hanger with all nail/bolt holes filled
 - Very High Capacity - Cullen FTH hanger
- All service holes in joists by follow on trades to be in accordance with Steico Technical Guide.

Multiple Beams and Stair Trimmers

- Uniform Line Load
 - 2 PLY 2 rows of 3.1x75mm nails at 300 ctrs
 - 3 PLY 3 rows of 3.1x75mm nails at 300 ctrs
 - 4 PLY 2 rows of M12 bolts at 400 ctrs
- Fixing of multiple I joists which support multiple floor joists to be via Cullen I-Clips in accordance with Cullen details below:
 - DJ 45mm 1 Clip between each joist
 - DJ 60mm 1 Clip between each joist
 - DJ 90mm 2 Clips between each joist
- Fixing of multiple I joists which support a single floor beam to be in accordance with the filler block details shown in the Steico Technical Guide. Specifically details G5a, G5b, G5c, G6, G7 & G8.
- With the exception of stair trimmers all floor beams to have full bearing on supporting wall panels, i.e. 89 or 140mm UNO.

Steelwork

- Unless noted otherwise Execution Class EXC2 applies to the works as a whole, including individual components and details of components.
- All steelwork should comply, unless noted otherwise, with National Structural Steelwork Specification (NSSS) for Building Construction 5th Edition CE Marking Version.
- All steelwork shall be shot blasted to Sa 2½ or BS 7079: Part A1
- Internal steelwork shall receive 80mm of approved zinc phosphate epoxy primer.
- All external steelwork shall (Receive 85mm of hot dip) Galvanized to BS EN 150 1461.

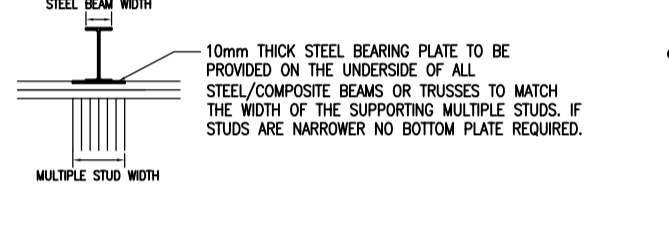

Roof Trusses

- All roof trusses secured to headbinder with fully nailed Cullen TC truss clips UNO.
- Girder trusses and roof beams to be have half truss clips to each side UNO.
- All roof beams and girder trusses to have full bearing on supporting wall panels, i.e. 89 or 140mm UNO. Truss specialist to ensure truss widths have been sized to suit bearing capacity of C16 headbinder.
- All roof trusses to be contractor designed by specialist. Any change to support positions or girder locations to be confirmed to Fairhurst once specialist design is available.
- Where roofs are not sarked (minimum 9mm osb or 22mm whitewood) all permanent roof bracing to be detailed by truss specialist and be in accordance with BS 5268: Part 3 and the recommendations of the Truss Rafter Association.
- Reliance on a plasterboard ceiling to the underside of the truss has made as standard to form the ceiling diaphragm. Fairhurst to be advised if plasterboard will not be provided as additional plan ceiling bracing may be required.
- Should timber beams or girder trusses be specified over stairwells it is the responsibility of the timber frame supplier and architect to confirm the use of timber is acceptable to meet fire and acoustic code requirements.

Roof Joists

- All roof joists secured to headbinder with fully nailed Cullen TA truss anchors UNO. Where I joists are used full depth web blocking to be provided between the flanges to each side to ensure all nail fixings are used.
- Where joist flanges exceed 50mm Cullen TA-1 framing anchors to be used to each side in lieu of truss anchors. Full depth web blocking to be provided between the flanges to each side to ensure all nail fixings are used.

Timber Frame Line & Point Load Notes:

- 40 Denotes dead and live unfactored uniformly distributed loads (with a 50/50 load split) from timber frame elements only.
- 40 Denotes dead and live unfactored point loads (with a 50/50 load split) from beam reactions, girder trusses etc from timber frame elements only which must be included in addition to uniformly distributed loads indicated. Equivalent increased line load to be determined from typical load dispersal detail below.

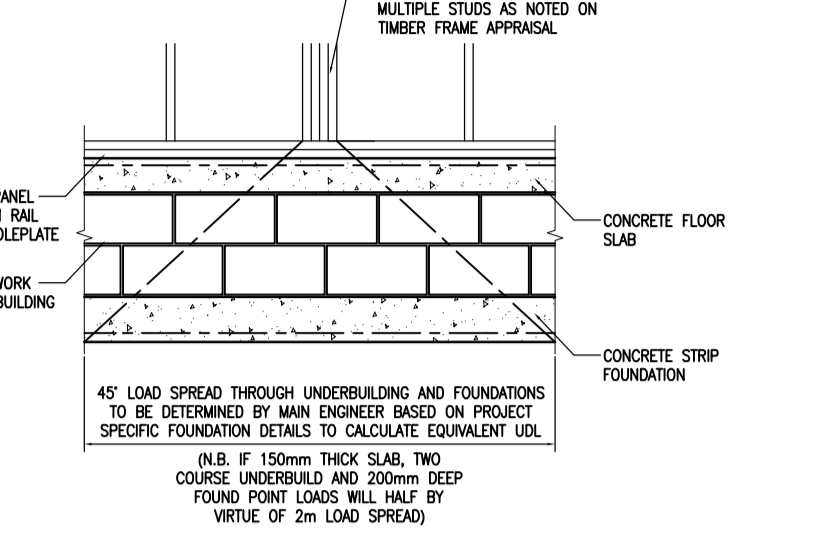

Load concentrations will occur on either side of openings in external and internal load bearing walls. Unless noted otherwise these should be calculated from the noted uniformly distributed load and allowed for in the design of the substructure.

- Denotes load bearing walls with a uniformly distributed load of 10kN/m and a point load of 10kN U.N.O. NB. load is applied per leaf at party walls, i.e. if house type is semi detached all party wall loads will be double.
- Denotes racking wall panels resisting short term wind loads. Noted wind loads transferred to floor slab by virtue of panel overturning.

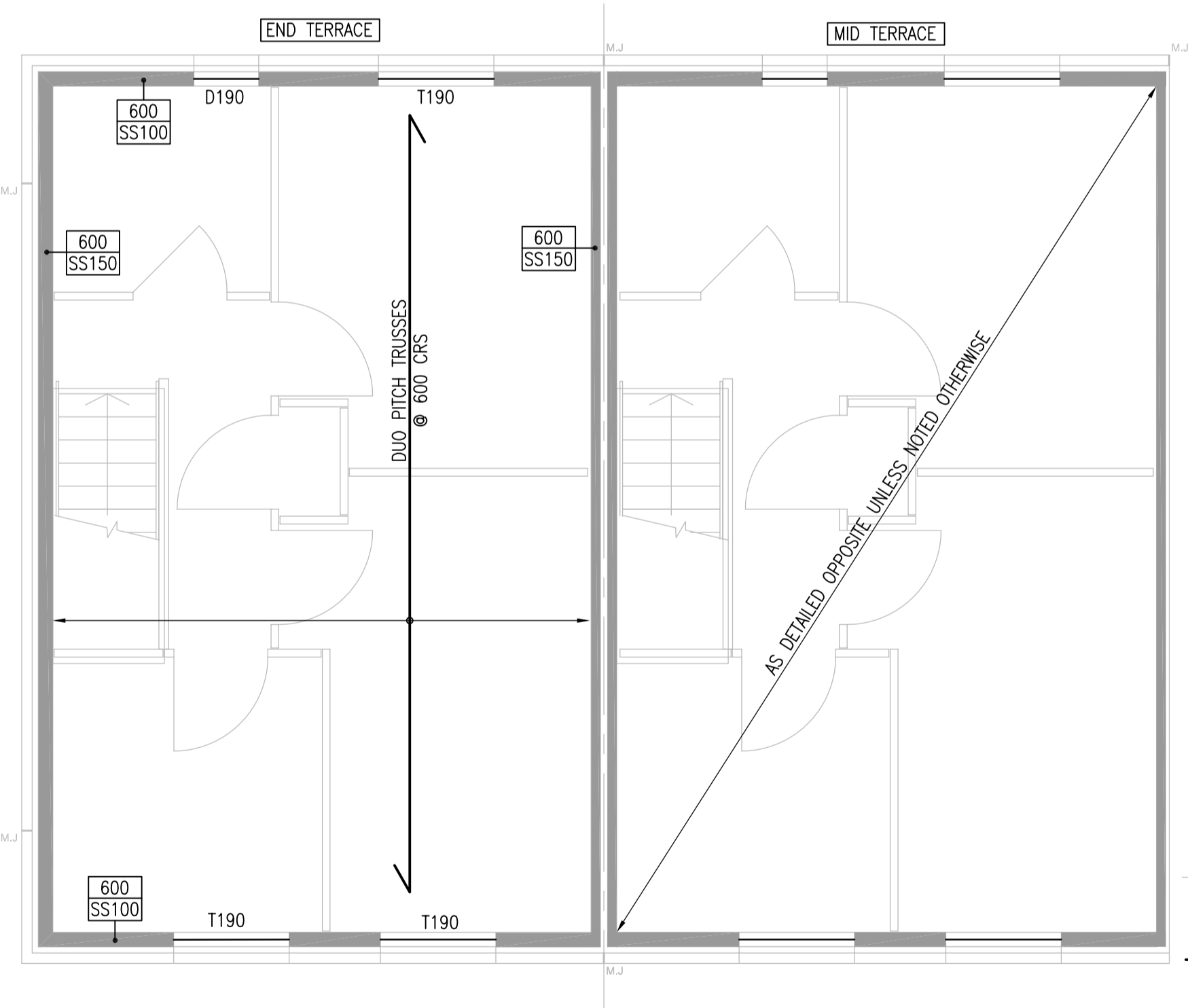

ROOF LAYOUT/1ST FLOOR WALLS
SCALE 1:50

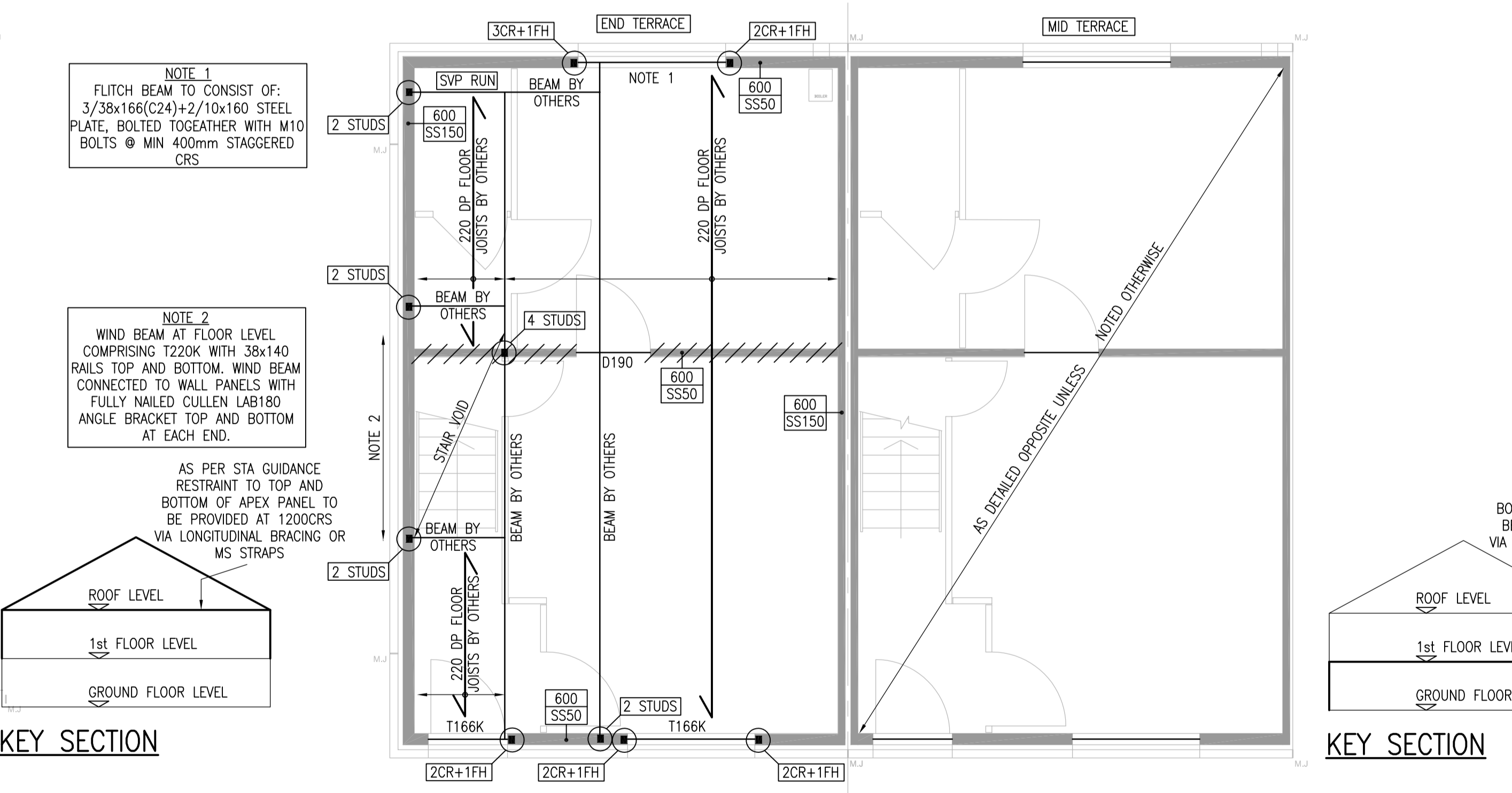

1ST FLOOR LAYOUT/GROUND FLOOR WALLS
SCALE 1:50

Rev.	Date	Description	Drawn	Checked	Approved

STANDARD WIND LOADINGS: TO ACCOUNT FOR CONSTRUCTION OF HOUSES ON VARIOUS SITES STANDARD WIND PRESSURES HAVE BEEN USED AS BELOW: AT RIDGE LEVEL = 1.05kN/m ² & AT EAVES LEVEL = 0.95kN/m ² WIND PRESSURES TO BE CHECKED ON A SITE BY SITE BASIS TO ENSURE NO GREATER THAN THE ABOVE FOR FUTURE SITES

IMPOSED LOAD CAPACITY OF FLOORS AS BELOW: MAXIMUM - 1.5kN/m ² AS OCCUPANCY A IN TABLE 1 BS 6399-1

THIS REGISTER IS A NON-EXHAUSTIVE LIST OF SIGNIFICANT RESIDUAL HAZARDS RELATING TO THE WORKS SHOWN ON THIS DRAWING THAT HAVE BEEN IDENTIFIED DURING THE DESIGN STAGE	
SIGNIFICANT RESIDUAL HAZARDS	DETAILS
IT HAS BEEN ASSESSED THAT THERE ARE NO RESIDUAL DESIGN HAZARDS PRESENT IN THE STRUCTURAL WORKS SHOWN ON THIS DRAWING THAT A COMPETENT CONTRACTOR WOULD NOT BE AWARE OF.	

Client: OREGON TIMBER FRAME

Project Title: BARRATT STAS AFFORDABLE HOUSE RANGE
Drawing Title: TIMBER FRAME APPRAISAL HOUSE TYPE ROSSDHU 1 OF 2

FAIRHURST
88 Queens Road, ABERDEEN, AB15 4YQ
Tel: 01224 321 222 Fax: 01224 323 201

Scale at A1: 1:50	Status: For Information	
Drawn: AJM	Checked: DD	Approved: BM
Date: OCT'20	Date: OCT'20	Date: OCT'20
Drawing No.: 140267/ROSSDHU/001	Revision: -	

Standard Appraisal Notes

Wall Panels

- All external walls to comprise 38x140 (C16) studs at maximum 600mm centres with 9mm osb cladding to cavity side nailed to S550 nailing specification UNO.
- All internal and party walls to comprise 38x89 (C16) studs at maximum 600mm centres with mid-height dwangs and plasterboard cladding UNO. If a wider wall construction is used for party walls adjacent to stairs 38x140 studs to be used.
- Where enhanced racking resistance is required internal walls will be clad with one or two layers of 9mm osb. For housing these walls are shown hatched as .
- Stud centres for all external wall panels can be averaged however, internal studs are set at the maximum centres noted.
- Cullen PWS-200 party wall straps to be provided at a minimum 1200mm horizontal centres U.N.O. All straps to be installed in accordance with the Cullen Technical Manual.

600
S550
SNT100

Wall Panels (cont'd)

- All timber lintels incorporated within the floor zone (upstand) supported on two full height studs U.N.O.
 - All timber lintels incorporated within the wall panel (downstand) supported on one cripple & one full height stud U.N.O.
 - Standard timber lintel and beam notation as below with lintels supported on minimum one cripple stud and one full height stud.
 - All timber lintels to be hard to the underside of the wall panel top rail with infill below to form the head and cill panels. For larger structural openings head and cill panels to have multiple continuous horizontal rails between the studs based on the spans below:
- | | |
|-------------------|----------------------------|
| S140 38 x 140 C16 | S140K 45 x 140 Kerto-S LVL |
| S166 45 x 166 C24 | S166K 45 x 166 Kerto-S LVL |
| S190 45 x 190 C24 | S190K 45 x 190 Kerto-S LVL |
| S220 44 x 220 C24 | S220K 45 x 220 Kerto-S LVL |
| S235 38 x 235 C24 | S235K 45 x 235 Kerto-S LVL |
-
- | | |
|---------------------|------------------------------|
| D140 2/38 x 140 C16 | D140K 2/45 x 140 Kerto-S LVL |
| D166 2/45 x 166 C24 | D166K 2/45 x 166 Kerto-S LVL |
| D190 2/45 x 190 C24 | D190K 2/45 x 190 Kerto-S LVL |
| D220 2/44 x 220 C24 | D220K 2/45 x 220 Kerto-S LVL |
| D235 2/38 x 235 C24 | D235K 2/45 x 235 Kerto-S LVL |
-
- | | |
|---------------------|------------------------------|
| T140 3/38 x 140 C16 | T140K 3/45 x 140 Kerto-S LVL |
| T166 3/45 x 166 C24 | T166K 3/45 x 166 Kerto-S LVL |
| T190 3/45 x 190 C24 | T190K 3/45 x 190 Kerto-S LVL |
| T220 3/44 x 220 C24 | T220K 3/45 x 220 Kerto-S LVL |
| T235 3/38 x 235 C24 | T235K 3/45 x 235 Kerto-S LVL |
-
- | | |
|--------|-------------------------------------|
| < 2.0m | - 1No continuous 38x140 rail |
| < 2.8m | - 2No continuous 38x140 rails |
| < 3.6m | - 3No continuous 38x140 rails |
| > 3.6m | - Project specific details required |

Site Nailing

- All site nailing to be in accordance with Fairhurst standard site nailing schedule which is generally as follows:
 - 300mm centres for 89mm kit.
 - 200mm centres for 140mm kit.
 - 200mm centres for all internal osb clad walls.
- Soleplates to be fixed to concrete floor slab or blockwork underbuild with SPIT HIT-M 8-60-92V either side of openings and at 900mm centres U.N.O.
- Ground floor holding down straps to be provided at all structural corners and at 2.4m centres between.
- Cullen FT-50 wall ties to be provided at a minimum density of 5.5 ties/m² at ground, first and second floor wall panels to secure any blockwork cladding to the timber frame.
- For medium to high rise timber frame Cullen HMT-50 wall ties to be provided at a minimum density of 7.4 ties/m² at third floor wall panels and above to secure any blockwork cladding to the timber frame.
- In addition to the above minimum densities additional wall ties to be provided at 225mm vertical centres adjacent to openings, corners and all expansion joints.
- Responsibility for ensuring compliance with minimum tie densities rests with the contractor to suit the external cladding which will vary on a project by project basis. Wall tie specification is based on a standard 50mm cavity, if a larger cavity is to be used please advise the timber frame engineer.

Fire

The timber frame specifications noted on the appraisal assumes there are no risks associated with fire during construction to neighboring buildings. If the fire risk assessment, undertaken by the timber frame specialist, notes this is not the case enhancements to the timber frame specification via fire rated materials to be made by the specialist.

Generally upgrades to the timber frame will comprise the use of fire rated wall panel sheathing, i.e. fermacell, and the use of fire rated floor decks and/or joists.

I Joist Floors

- All floor joists to be 220 Dp Steico joists of type and centres noted with a single or double 220 Dp LVL edgebinder. Where joists span parallel with external walls perpendicular sprockets to be provided at 600mm centres between the wall and first joist as standard. All floors to be glued and screwed in accordance with NHBC requirements.
- External Wall Panel Blocking. If single edgebinders are used below 140mm external walls then additional blocking will be required within floor zones to spread the load from studs to wall panels below. The alternative to the additional blocking noted below would be the use of double edgebinders.
 - 2 or 1+1 Studs - Edgebinder + single Steico blocking
 - >2 or >1+1 Studs - Edgebinder + single LVL blocking
 - >5 or >4+1 Studs - Edgebinder + double LVL blocking
 - Key Elements - Edgebinder + double LVL blocking
- Internal Wall Panel Blocking. Single Steico midfloor blocking to be provided in the floor zone over internal load-bearing walls to transfer loads through the floor zone. For multi storey buildings double Steico or LVL blocking will be required as noted on the appraisal key section.
- To account for load concentrations enhanced midfloor blocking to be provided below multiple studs as per the below.
 - 2 or 1+1 Studs - Double Steico blocking
 - 3 or 2+1 Studs - Double Steico blocking
 - >3 or >2+1 Studs - Double LVL blocking
 - Key Elements - Double LVL blocking
- Party Wall Panel Blocking. In addition to floor panel edgebinder party walls to be blocked with solid timbers to suit the wall width. All incoming Steico floor joists to have webs packed with full depth timbers.
- Where multiple joists are specified the adjacent floor joists must be detailed from the centre line of the multiple member. The position of any floor trimmers to suit SVP voids etc. is indicative and should trimmer positions be revised to suit joist setting out etc. the timber frame fabricator must forward floor panel details for review.
- All floor joist hangers to be fully nailed Cullen UH hangers with receiving joist (if not solid) to have web packers fitted as standard.
- All multiple member hangers to be fully nailed Cullen UH hangers with receiving joist (if not solid) to have web packers fitted as standard. Where higher loads require to be transferred enhanced hangers to be used as below:
 - Medium Capacity - Cullen HUH hanger with all nail holes filled
 - High Capacity - Cullen MH hanger with all nail/bolt holes filled
 - Very High Capacity - Cullen FTH hanger
- All service holes in joists by follow on trades to be in accordance with Steico Technical Guide.

Multiple Beams and Stair Trimmers

- Uniform Line Load
 - 2 PLY 2 rows of 3.1x75mm nails at 300 ctrs
 - 3 PLY 3 rows of 3.1x75mm nails at 300 ctrs
 - 4 PLY 2 rows of M12 bolts at 400 ctrs
- Fixing of multiple I joists which support multiple floor joists to be via Cullen I-Clips in accordance with Cullen details below:
 - DJ 45mm 1 Clip between each joist
 - DJ 60mm 1 Clip between each joist
 - DJ 90mm 2 Clips between each joist
- Fixing of multiple I joists which support a single floor beam to be in accordance with the filler block details shown in the Steico Technical Guide. Specifically details G5a, G5b, G5c, G6, G7 & G8.
- With the exception of stair trimmers all floor beams to have full bearing on supporting wall panels, i.e. 89 or 140mm UNO.

Steelwork

- Unless noted otherwise Execution Class EXC2 applies to the works as a whole, including individual components and details of components.
- All steelwork should comply, unless noted otherwise, with National Structural Steelwork Specification (NSSS) for Building Construction 5th Edition CE Marking Version.
- All steelwork shall be shot blasted to Sa 2½ or BS 7079: Part A1
- Internal steelwork shall receive 80mm of approved zinc phosphate epoxy primer.
- All external steelwork shall (Receive 85mm of hot dip) Galvanized to BS EN 150 1461.

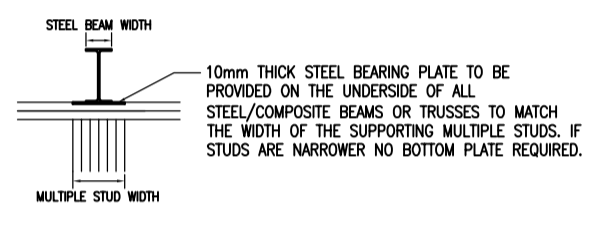

Roof Trusses

- All roof trusses secured to headbinder with fully nailed Cullen TC truss clips UNO.
- Girder trusses and roof beams to be have half truss clips to each side UNO.
- All roof beams and girder trusses to have full bearing on supporting wall panels, i.e. 89 or 140mm UNO. Truss specialist to ensure truss widths have been sized to suit bearing capacity of C16 headbinder.
- All roof trusses to be contractor designed by specialist. Any change to support positions or girder locations to be confirmed to Fairhurst once specialist design is available.
- Where roofs are not sarked (minimum 9mm osb or 22mm whitewood) all permanent roof bracing to be detailed by truss specialist and be in accordance with BS 5268: Part 3 and the recommendations of the Truss Rafter Association.
- Reliance on a plasterboard ceiling to the underside of the truss has made as standard to form the ceiling diaphragm. Fairhurst to be advised if plasterboard will not be provided as additional plan ceiling bracing may be required.
- Should timber beams or girder trusses be specified over stairwells it is the responsibility of the timber frame supplier and architect to confirm the use of timber is acceptable to meet fire and acoustic code requirements.

Roof Joists

- All roof joists secured to headbinder with fully nailed Cullen TA truss anchors UNO. Where I joists are used full depth web blocking to be provided between the flanges to each side to ensure all nail fixings are used.
- Where joist flanges exceed 50mm Cullen TA-1 framing anchors to be used to each side in lieu of truss anchors. Full depth web blocking to be provided between the flanges to each side to ensure all nail fixings are used.

Timber Frame Line & Point Load Notes:

- Denotes dead and live unfactored uniformly distributed loads (with a 50/50 load split) from timber frame elements only.
 - Denotes dead and live unfactored point loads (with a 50/50 load split) from beam reactions, girder trusses etc from timber frame elements only which must be included in addition to uniformly distributed loads indicated. Equivalent increased line load to be determined from typical load dispersal detail below.
-
- Denotes load bearing walls with a uniformly distributed load of 10kN/m and a point load of 10kN U.N.O. NB. Load is applied per leaf at party walls, i.e. if house type is semi detached all party wall loads will be double.
 - Denotes racking wall panels resisting short term wind loads. Noted wind loads transferred to floor slab by virtue of panel overturning.

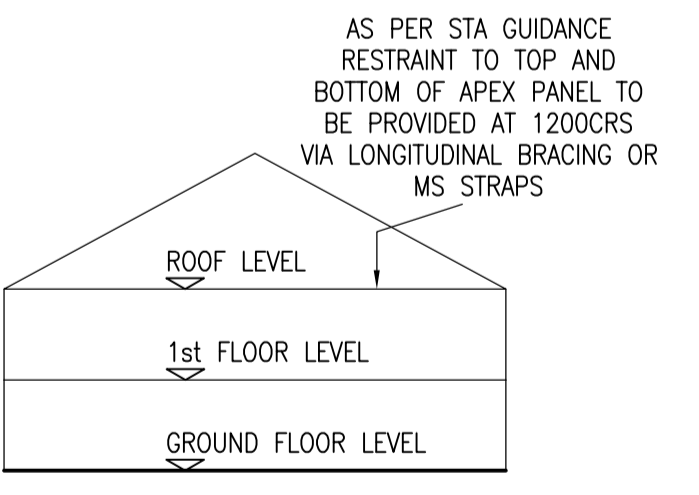
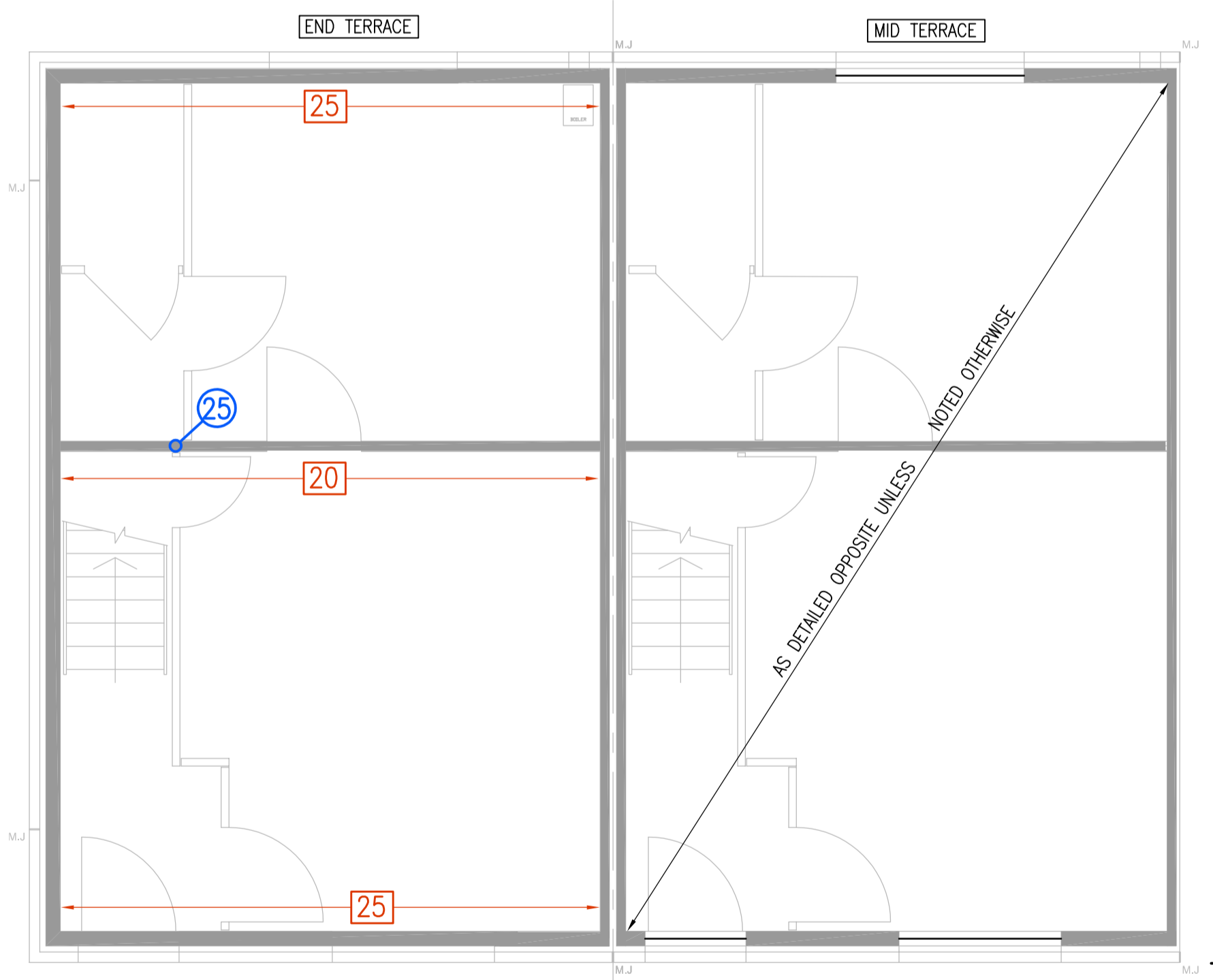

LINE AND POINT LOADS
SCALE 1:50

Rev.	Date	Description	Drawn	Checked	Approved

STANDARD WIND LOADINGS: TO ACCOUNT FOR CONSTRUCTION OF HOUSES ON VARIOUS SITES STANDARD WIND PRESSURES HAVE BEEN USED AS BELOW: AT RIDGE LEVEL = 1.05kN/m ² & AT EAVES LEVEL = 0.95kN/m ² WIND PRESSURES TO BE CHECKED ON A SITE BY SITE BASIS TO ENSURE NO GREATER THAN THE ABOVE FOR FUTURE SITES	IMPOSED LOAD CAPACITY OF FLOORS AS BELOW: MAXIMUM - 1.5kN/m ² AS OCCUPANCY A IN TABLE 1 BS 6399-1
------------------------------------------------------------------------------------------------------------------------------------------------------------------------------------------------------------------------------------------------------------------------------------------------------------------------------------	-----------------------------------------------------------------------------------------------------------------

END TERRACE DESIGNED AS SEMI-DETACHED UNIT MID TERRACE DESIGNED IN A TERRACE OF MIN. 3No. UNITS	
THIS REGISTER IS A NON-EXHAUSTIVE LIST OF SIGNIFICANT RESIDUAL HAZARDS RELATING TO THE WORKS SHOWN ON THIS DRAWING THAT HAVE BEEN IDENTIFIED DURING THE DESIGN STAGE	
SIGNIFICANT RESIDUAL HAZARDS	DETAILS
IT HAS BEEN ASSESSED THAT THERE ARE NO RESIDUAL DESIGN HAZARDS PRESENT IN THE STRUCTURAL WORKS SHOWN ON THIS DRAWING THAT A COMPETENT CONTRACTOR WOULD NOT BE AWARE OF.	

Client: OREGON TIMBER FRAME

Project Title: BARRATT STAS AFFORDABLE HOUSE RANGE

Drawing Title: TIMBER FRAME APPRAISAL HOUSE TYPE ROSSDHU 2 OF 2

FAIRHURST
88 Queens Road, ABERDEEN, AB15 4YQ
Tel: 01224 321 222 Fax: 01224 323 201

Scale at A1: 1:50 Status: For Information

Drawn: AJM	Checked: DD	Approved: BM
Date: OCT'20	Date: OCT'20	Date: OCT'20

Drawing No.: 140267/ROSSDHU/002 Revision: -



BARRATT
— HOMES —

BARRATT SCOTLAND
SPECIFICATION

-21 CALEDONIA & ALBA RANGE

2022 TECHNICAL STANDARDS

DETACHED & ATTACHED
TWO & THREE STOREY
TIMBER FRAME HOUSES

REVISIONS INDEX

BNS 2022 Timber Frame Spec based on BNS 2020 Spec Revision C:

REVISION - 25/10/23 MID FLOOR SOUND INSULATION REMOVED.

FOUNDATIONS/SUBSTRUCTURES/GROUND FLOORS

All materials and components must be suitable for their intended purpose and location and must be manufactured and installed in accordance with all relevant, current British Standards and codes of practice, building regulation requirements and manufacturer's specification.

Surface soil and vegetable matter to be removed from the entire construction area, including the building footprint, prior to commencement of works.

BLOCKWORK GENERALLY

All blockwork to be in accordance with BS EN 771-4:2003 and BS 5628. In addition to any technical requirements listed in this specification all concrete blocks must be solid and suitable for their intended location.

References to 'Min.C.S.' denote 'MINIMUM compressive strength'.

References to 'Min.T.R.' denote 'MINIMUM thermal resistance'.

References to 'Max.T.C.' denote 'MAXIMUM thermal conductivity'.

MORTAR

Mortar to be group (iii) to BS 5628 Part 3:2005 or strength class M4 to BS EN 998-2:2003

Refer to Engineers drawings & specification for mortar mix.

DPC

Horizontal D.P.C.'s to be minimum 150mm above adjacent ground level and to be either 'Hiload' or similar bituminous based felt D.P.C. (to BS 6398:1983) or 500 microns black polymeric (2000g) to B.S. 6515:1984. DPC tray to all firestops and around all opening in the external envelope.

FOUNDATIONS

Refer to Consulting Engineers drawings and specification for full site-specific foundation details.

Concrete strip foundations all in accordance with Scottish Building Standards Section 1 – depth below ground level subject to proximity of drains and local site conditions and a minimum of 600mm below finished ground level to formation level.

SUBSTRUCTURE

Walls below floor level to be 260mm overall thickness cavity wall comprising 2 no. leaves of 100mm thick Celcon Air Crete concrete blockwork (min C.S. 3.2 N/mm²) with inner leaf to support concrete floor slab, edge of slab to be wrapped in DPM and folded under DPC under timber soleplate. Thermal Economics ThermaEdge (525mm width). Timber Frame Supplier to fix top edge to full width of underside of sole plate (beneath DPC) using stainless steel staples prior to installation of sole plate fixings. To be draped tightly down inside face of cavity fixed to blockwork with 30mm galvanised nails at 1500mm centres max. Foil finish facing into cavity. Corners to be covered with 340mm wide strip of ThermaEdge fixed with either 30mm galvanised twist nails or using Thermal Economics Alu tape. Cavity filled to 225mm below floor level with weak mix concrete below ground level. "Celcon" Foundation block (min C.S. 3.2 N/mm²) to a depth as per manufacturers recommendations and site specific Engineers information. Blocks to be manufactured in accordance with B.S. 6073, used in compliance with B.S. 5628-3 or supported by relevant Agreement Certificates.

External base course to be 100mm medium-density facing stone external leaf to DPC level and terminated with expanded metal render stops to receive render above.

INSULATED DWELLING GROUND FLOORS

Refer to house type specific SAP for U-Value

Refer to Engineers drawings and specification for details of fully suspended ground floor slabs.

Overall floor build up consists of power floated concrete slab, to engineer's details on 1200 gauge DPM over Thermal Economics Platinum Ground Floor Insulation. (REFER TO APPENDIX 2019A-D FOR HOUSE TYPE SPECIFIC INSULATION THICKNESS)

All DPM joints to be sealed and lapped MIN 300mm dressed under wall DPC. Insulation laid on 50mm sand blinding with suitably compacted material below.

Where gas protection measures are required refer to Architects and Engineers site specific details showing gas membranes, all in compliance with BRE and NHBC Guidelines.

GARAGE FLOORS

Concrete in-situ slab as described above but without the inclusion of insulation, subject to site conditions dictating otherwise. Integral garage floor slabs to be laid 100mm lower than main dwelling slab with 50mm fall towards front door.

EXTERNAL WALLS: SINGLE, 2 & 3 STOREY DWELLINGS

All external timber to be pressure-impregnated with preservative prior to delivery to site. Structural timber to be to BS 5268: Part 2: 2002.

EXTERNAL WALL CONSTRUCTION

Max U-Value of 0.22 W/m²K

External render coating on 100mm 7.0N block external leaf (Min.C.S. 7.0 N/mm, Min. T.R. 0.333 m²K/W, Max density 1400Kg/m³), 50mm cavity fire stopped (38 x 50mm whitewood timber fire stops) at all corners, junctions and external opening (excluding party wall). Protect Thermo TF200 factory fitted to 9mm OSB BBA sheathing fixed to 38x140mm C16 CLS framing at 600mm centres, 140mm mineral wool insulation (REFER TO APPENDIX 2019A-D FOR HOUSE TYPE SPECIFIC K VALUE) friction fitted on site and frame finished with 15mm duplex vapour check taper edged Wallboard with joints taped, filled and prepared for decoration. Applicable house types have additional layer of 9mm OSB to front and back external walls, refer to working drawings.

Pre-bent stainless steel wall ties (minimum 4.4 per square meter) at 600mm centres horizontally and 450mm centres vertically and at 225mm centres at door external opening jambs. On single and 2 storey dwellings, wall ties to be 2.8mm thick. On 3 storey dwellings, wall ties to be 4mm thickness.

Slim line cavity vents to be provided at 900mm ctrs as follows:

- 1) Above dpc level,
- 2) Above first floor fire stop,
- 3) Above first floor ceiling fire stop on gables
- 3) Each side of door/window/gasbox lintels.

INTEGRAL GARAGE WALL CONSTRUCTION (Insulated)

Max U-Value of 0.22 W/m²K

From internal face, 15mm Gyproc WallBoard Duplex with vapour control layer, fixed to 38x140mm C16 CLS framing at 600mm centres. 140mm wool insulation (REFER TO APPENDIX 2019A-D FOR HOUSE TYPE SPECIFIC K VALUE) friction fitted on site, 9mm OSB BBA sheathing with 15mm Gyproc Wallbord plasterboard with joints taped, filled and prepared for decoration.

No services to penetrate the above wall. Where services are shown on plan on house side additional framing of 38x50mm battens and 12.5mm WallBoard to be fitted and on garage side of separating partition these will have surface mounted wiring and boxes.

INTEGRAL GARAGE WALL EXTERNAL CONSTRUCTION (Non insulated)

External render coating on 100mm 7.0N block external leaf (Min.C.S. 7.0 N/mm, Max density 1400Kg/m³), 50mm cavity fire stopped (50 x 50mm whitewood timber fire stops) at all corners, junctions and external opening. Breather membrane factory fitted to 9mm OSB BBA sheathing fixed to 38x89mm C16 CLS framing at 600mm centres.

External walls frame finished with 15mm taper edged Gyproc WallBoard with joints taped and filled in prepared for decoration.

NOTE: Insulation is NOT required within external walls panels around garages.

PARTY WALL CONSTRUCTION

Max U-Value of 0.20 W/m²K

Two separating wall timber frame leaves formed with 9mm OSB BBA sheathing fixed to 38x89mm C16 CLS framing at 600mm centres with a 50mm cavity between frames. 90mm Superglass Timber & Rafter Roll 40 within stud. Cavity full fill insulated by timber frame manufacturer with 60mm Superglass TF Party Wall Roll and 50x300mm insulated cavity barrier to edges of party wall cavity. Timber frame finished with 19mm Gyproc Plank laid horizontally and 12.5mm taper edged Gyproc WallBoard with joints taped, filled and prepared for decoration. Moisture resistant plasterboard to be utilised in wet areas. No services to penetrate the above wall. Additional framing of 38x50mm battens and 12.5mm WallBoard to be fitted where required to conceal services. Apex panel to be 50mm lower than roof trusses.

All to achieve 60 minute (Medium Duration) fire resistance.

Party wall at external junction to have 1no. vertical ARC Party Wall Barrier (PWTCB50 – White) fitted with external cavity. PWTCB50 barrier to extend down to top of foundation block. All ARC Vertical TBC cavity fire barriers compression fitted within cavity. Flanges of barriers to be fixed with clout nails / staples at 150mm centres. Wall ties NOT to be fixed through cavity barrier. Horizontal external timber barrier and horizontal party wall barriers at mid floor and top floor ceiling (ARC TCBTT50 – YELLOW) to tightly butt against vertical wall barriers at party walls. Cavity barriers must continue to base of cavity.

All party walls to be taken up to underside of roof line and fire-stopped using ARC TCB (TCB300/65 – WHITE) between spandrel panel wall head and roofing felt and 1 no layer 60mm stone/rock mineral wool packed tight between tile battens to underside of roof tiles.

Separating walls to achieve minimum airborne sound insulation level of 56dB DnT,w and a maximum impact sound transmission of 56dB L'nT,w. Close external abutting cavity with Isover cavity closer to prevent flanking transmission. DPC to be located at floor level in line with DPC in external walls and continuous with DPM. **NOTE - SOUND TESTS TO BE CARRIED OUT UPON COMPLETION.**

SINGLE LEAF PART WALL APEX PANEL

Single leaf apex panel to be used only with STEWART MILNE TIMBER SYSTEMS (SMTS). Double party wall within roof space when using OREGON TIMBER FRAME (OTF)

Single leaf prefabricated party wall apex panel between semi-detached and terraced house types to achieve one house fire resistance.

Single leaf apex panel to be constructed with 47x70mm C16 grade square edge and planed timber studs at maximum 600mm centres, top and bottom rails and dwangs. Pre-fitted either side with 1 layer 15mm thick square edge Fermacell boards, fixed either side of panel with 3.9x45mm Fermacell self counter-sinking screws at 250mm centres to perimeter of board, and all intermediate studs. Party wall apex panels to have no cavity insulation between the studs. 38x140mm continuous timber, along top of exposed headbinder of timber kit party wall, with blocking as required to fix ceiling bracing. ARC 'U' Barrier (UB100 – Orange) fitted across top of spandrel panel underneath roof covering. Push fitted over spandrel panel, ensuring no gaps and tightly butted. 60mm mineral wool laid across felt at party wall head junction between tile battens from eaves to ridge, on top of the roof membrane, ensuring it extends the full width of the party wall panel below.

. Rafter bracing fixed to 38x 89mm ledger site fixed to face of pre-clad apex panel to support end of windbracing. Ledger to follow pitch of roof. 103x305mm nail plates at 1200mm centres along bottom of apex panel, fixed with 4 number 3.75x75mm nails to apex panel and headbinder.

Party wall apex panels to be set 50mm lower than roof truss profile.

Apex panel to be fixed to headbinder with 90mm skew nails at 300mm centres from both sides.

Spandrel panel joint – apex panels secured together using angled screw fixings. With 9mm thick x 97mm wide Magply board cover strip to cover joint between the two prefabricated panels.

Apex spandrel panels to achieve Minimum airborne sound insulation of 56dB $D_{nT,w}$ in accordance with the Building Standards.

All to achieve 60 minute (Medium Duration) fire resistance.

MOVEMENT JOINTS

Movement joints to be formed vertically at locations as described below. Unless otherwise stated, movement joints shown on house type drawings are for non-staggered terraces of up to 4 units. Notwithstanding any such locations, the location and width of movement joints in all external masonry panels (including freestanding external boundary walls) should be assessed having regard to the geometry of each particular terrace or wall configuration in accordance with BS 5628-5:1985 and block manufacturer's recommendations. Joints in external leaf to be filled with cellular polyethylene or foam rubber and sealed with two-part polysulphide sealant to match colour of render coating as closely as possible. Wherever possible, joints should be located behind rainwater pipes. Additional wall ties to be installed in the cavity wall max 225mm to each side of the joint at 225mm vertical centres in accordance with BS EN 846-5:2000 and – in Sovereign Range only – proprietary flat-strip debonded ties to be installed across joint at 450mm vertical centres.

LINTOLS

Lintols to be provided over all structural openings including meter boxes in accordance with drawings and lintol schedules. Lintol references are generally those of I.G. Lintols Ltd. and denote pressed steel type lintols designed in accordance with BS 5977:1981, galvanised to BS 729:2001. Any alternatives must be approved and satisfy all the above requirements. Where IG references are not given the lintols are to be as detailed in Structural Engineer's calculations.

All lintols must bear on full (NOT CUT) blocks. Cavity trays / damp proof protection must be provided over all external openings either separately or as a combined part of the lintol to satisfaction of Local Authority. Minimum 2 no. weep holes per opening to be provided spaced at maximum 450 intervals. Adequate end bearings of 150mm minimum must be provided (any reduction must be to satisfaction of Structural Engineer) and lintol to be firmly bedded in mortar.

Pad stones to be provided in accordance with Structural Engineer's Design where necessary. Manufacturer's recommendations for providing adequate fire resistance should be followed.

Cold bridge paths should be avoided and adequate insulation measures incorporated, depending upon lintol profile, in accordance with manufacturer's specification. All steelwork to be zinc coated and painted with bitumen.

STEELWORK

Steelwork to be fitted as per drawings to structural engineers requirements.

All steelwork to have a minimum of 150mm bearing at each end on suitable concrete pad stone to engineers recommendations.

CAVITY TRAYS & FLASHINGS

All flashings to be in milled lead sheet to BS 1178:1982. Code 4 lead flashings (stepped where necessary) to be provided where roofs abut blockwork. All flashings to be dressed up wall min. 150mm above surface of tile. Cavity trays to be linked to flashings in all cases and stepped in the case of a stepped flashing. Cavity trays must rise minimum 75mm across cavity. Code 4 lead soakers to be provided at each tile overlapped by flashings. Valleys to be lined with Code 5 lead.

INTERNAL STANDARD NON-LOAD BEARING AND LOAD BEARING PARTITIONS/FLOORS/DOORS /STAIRS

LOAD BEARING

Where partition is loadbearing minimum 89mm x 38mm C16 stud partitions with studs at 600mm c/c and mid row dwangs with 1 No. layer 9mm OSB, 1 No. layer 15mm Gyproc Wallboard plasterboard taped & filled to both sides. Horizontal D.P.C. to be located below all ground floor partitions.

NON- LOAD BEARING

Where partition is non-loadbearing minimum 75mm x 38mm s.w stud partitions with studs at 600mm c/c and mid row dwangs with 1 No. layer 12.5mm Gyproc Wallboard 10 plasterboard taped & filled to both sides. Horizontal D.P.C. to be located below all ground floor partitions.

NOISE REDUCING PARTITIONS (2 STOREY HT's)

Where internal partitions are separating apartments from apartments, an apartment and an internal space and a room containing a W.C from a Living Room, Dining, Study or Bedroom – 25mm min thick acoustic insulation quilt to be installed between the studs.

To achieve minimum 40dB Rw to comply fully with Clause 5.2.1 of the Scottish Building Standards.

PROTECTED ENCLOSURE PARTITIONS (3 STOREY ONLY)

Protected enclosure separating partitions to be 'short duration' fire resistance & constructed of either 89mmx38mm CLS C16 sw stud partitions or 38 x 75mm s.w. stud partitions at 600mm c/c and mid row with 15mm Gyproc Wallboard taped & filled to both sides.

- 1) 15mm Gyproc Moisture Resistant plasterboard to Bathroom & or En-suite wet areas only i.e. around showers/baths side with both sides taped & filled joints.
- 2) Where such partitions separate a room containing a W.C. from a Living Room, Dining Room, Study, Bedroom, 25mm min. thickness acoustic insulation quilt to be installed between the studs.
- 3) Separating partitions between apartment and bedroom from circulation space or each other to have minimum 25mm thick acoustic insulation quilt to be laid between the studs.

To achieve minimum 40DB Rw to satisfy Section 5 of 2022 Scottish Building Standards.

All Studs to be fixed to G.F. slab (where applicable) as per Oregon nailing schedule. Horizontal d.p.c to be located below all ground floor partitions.

FIRE RESISTANT DOORS

Any doors linking accommodation to garages to be fire resistant grade FD30s and contained within frames incorporating cold smoke seals providing "short duration" fire resistance.

All doors within protected stairwell/hallways in 3 storey dwellings to be FD30s rated. This includes all store with ignition source, bedroom, kitchen, living room, dining room doors accessed off the protected enclosure. Bathroom doors do not require to be fire rated, provided the FD30 stair enclosure is extended to contain bathroom, with no openings. With exception of store doors that contain no ignition source, all doors to be fitted with self-closing device. Rising butt hinges are not acceptable. Door closers to be sized to suit the door leaf they are fitted to, and must be capable of closing the door into the latched position, taking account of the smoke seals.

UPPER FLOORS

Oregon Timber Frame floor cassette make up to be used in all cases for upper floors. The joist layouts prepared by the manufacturers must be adhered to in terms of setting out to ensure structural stability in all cases.

OTF products must be stored, handled and installed strictly in accordance with manufacturer's recommendations

OTF floor cassette consists of 220/240mm Engineered STEICO Joists fixed at (and not exceeding) 600mm centres with 15mm OSB deck nailed to top of joists. All such floors to be finished with 18mm thick peel clean chipboard or equivalent flooring grade moisture resistant T&G Type P5 chipboard to B.S.5669. Flooring to be fixed with 63mm Quick Drive screws at 200mm around the perimeter and at 300mm centres intermediately. Flooring to be glued to sub-floor using D4 glue or Caberfix adhesive and all board joints with D3 glue. Refer to OTF specification for further information on first floor components.

Trimming to be provided where necessary to allow for stair case openings, horizontal waste/soil pipes and s.v.p.'s all in accordance with plans prepared by OTF or their representatives.

Min. 38 x 38mm noggings to be fixed with proprietary 'Z clips' to top flanges of STEICO joists around all perimeters for fixing edges of floor decking.

Stud partitions parallel to the floor span but not located immediately over STEICO joists to be supported on min. 35 x 72mm noggings at max. 600mm ctrs. between joists - noggings to be fixed to top flange of beams using proprietary 'Z clip' hangers.

Hangers with blocking, if required, installed as the design engineering provided by the I-pro calculation suite

Unless otherwise stated, where hot water cylinders are located over stair bulkheads, support framing to be 97 x 38mm C16 s.w. at max 400mm ctrs.

Notching & Drilling.

Timber STEICO joists may have circular or rectangular holes carefully formed within the webs but only strictly in accordance with the manufacturer's published diagrams, tables and general cutting criteria - the size and spacing of such holes and their location with respect to the end of the beam is absolutely critical.

Under no circumstances should the top or bottom joists flanges be notched or drilled.

Laminated ply beams may only be notched and drilled within the limits shown on the following detail. Notches and drillings in laminated ply beams to be at least 100mm apart horizontally.

Special instructions should be obtained from the Structural Engineer when notching and drilling does not meet the above guidelines or is needed close to heavy loads, such as those from partitions, cisterns, cylinders and stair trimming.

If structural strength is impaired by notching or drilling, the element should be replaced or correctly repaired (to manufacturer recommendations or remedial detail in the case of a damaged joist).

2-Storey Dwellings.

Where floor void is above integral Garage, void to be 1 no. layer 15mm Gyproc Wall board with all joints filled and taped, overlaid with 1 layer 140mm Superglass Timber & Rafter Roll 35 and 1 layer 90mm Superglass Timber & Rafter Roll 35.

Where ground floor plan features a store located below straight-flight staircase, stair soffit to be lined with 1 layer 15mm Gyproc Wallboard.

Where store occurs below winder staircase, 60mm mineral wool to be pinned to underside of flight and soffit to be wet-plastered over expanded metal mesh formed to suit staircase profile.

All intermediate floors within the dwelling must achieve a minimum of 43dB Rw airborne sound insulation.

Comprised of 220/240mm deep I-beams and laminated ply beams fixed at (and not exceeding) 600mm centres with 18mm P5 'Caberdeck' chipboard flooring on 15mm OSB-3 sub-floor and 15mm 'Gyproc Wallboard' ceilings. Moisture resistant plasterboard to wet areas.

All as per this Specification unless joist centres changed to specific house type where, in certain circumstances, joist centres may be closer.

STAIRCASE

Straight and tapered stair flights and landings to be formed strictly in accordance with current 2022 Scottish Building Regulations, section 4.3. Tapered goings: Equally sized, measured along center line of flight and not less than the straight goings.

Private Stair

Min tapered tread: 50mm
2riser+going = 550 Min, 700 Max.
goings: 225mm Min.
risers: 220mm Max.
pitch: 42° max pitch.
Width: Min clear width 900mm with continuous handrail on 1 side.
Min clear width 800mm with handrail fitted both sides (continuous handrail on 1 side).
Height: 2000mm clear above pitch line.

'Any Other' Stair

Min tapered tread: 50mm
2riser+going = 550 Min, 700 Max.
Goings: 250mm Min.
Risers: 170mm Max.
Pitch: 34° max pitch.
Width: Min clear width 900mm with continuous handrail on 1 side to single dwelling.
Height: 2000mm clear above pitch line.

Timber handrails and balustrading to be provided between flights with newel posts at top and bottom of flights and at change in direction of tapered treads.

Balustrading spaced to prevent the passage of 100 dia sphere.

Handrail height measured 900mm above pitch line of stair. (Handrail height min 840mm, max 1000mm, measured vertically above pitch line of flight or landing surface) Where a handrail is provided to only 1 side of a private stair flight, the side on which a handrail is not fixed should permit installation of a second handrail at a future date. A second handrail will provide additional support to a person using the stair and may be installed provided a clear width of 800mm is maintained. Minimum landing length to be either 900mm with handrail on 1 side or 800mm with handrail fitted both sides.

Protective barriers and handrails to have balustrade which will not permit the passage of a 100mm dia. sphere.

Newel posts to be provided, where required.

Flights to consist of min 3 & max 16 risers.

Ramps & Landings

Gradient - 1:20 to not more than 1:12 max Flight length related to gradient e.g.

1:20 – 10m, 1:15 – 5m, 1:12 – 2m

Width: 1.0m min effective width between any handrails/guard kerbs.

Landings: to be provided top & bottom of every flight with effective width not less than that of the flight. Landing length 1.5m min.

Handrails to be fitted to both sides of ramp which has a flight longer than 2m or where change of level is more than 600mm.

GLAZING

All windows to be double glazed PVC with thermal inserts and warm edge spacers to achieve a U-value of 1.40 W/m²K and a G-value of 0.73

Window style to be in accordance with house type elevations and schedules. Obscured glazing to front door, bathroom, en suite and cloakroom windows, and also landing window if directly overlooking an adjacent window within 13 metres. In accordance with 2022 Scottish Building Standards Section 4.8 all glazing should be designed to resist collision from occupants in accordance with BS6262 part 4: 2005; all glazing below 1500mm above finished floor level in both doors and sidelights within 300mm of door jamb and all other areas of glazing below 800mm above finished floor level must be either:-

- a) toughened or laminated and break safely to BS 6206:1981, or
- b) robust i.e. 8mm annealed glass in panes not exceeding 1.1m in both height and width, or
- c) 6mm annealed glass in small panes, i.e. maximum width 250mm and area 0.5m².

All opening lights (and doors) to be fitted with draught proof strips. All upper floor opening lights of windows to be fitted with EASY-CLEAN hinges which comply with clauses 10.2, 10.3 and 10.4 of BS 8213 : Part 1:2004. All opening lights where the bottom of the window opening is less than 800mm above FFL, and also at ground floor level, where the difference between external ground and FFL exceeds 600mm, must be fitted with protective barriers in front of windows fixed 800mm AFFL.

ALL outward opening windows over footpaths and opening lights at second floor to be fitted with suitable restrictors to prevent the opening of the window by more than 100mm - restrictors to be easily by-passed by an adult without use of tools and located out of reach of small children.

EMERGENCY ESCAPE WINDOWS

All habitable rooms (apartments) at first floor level must be provided with an escape window of a size to give an unobstructed opening that is at least 450mm high and 450mm wide and at least 0.33m² in area. The openable area of the window should not be more than 1100mm above the finished floor level, in accordance with 2022 Scottish Building Standards Section 2.9.4. No locks or locking handles are to be fitted to escape windows other than restrictors which must be easily opened by an adult but prevent a child at sill level from opening a window beyond 100mm.

ROOF WINDOWS

Keylite Thermal Window (G Factor 0.76) / Thermo Plus (G Factor 0.71) or equal roof window. Max U-value of 1.60 W/m²K

ROOFS/FLOORS/CEILINGS

ROOF

Unless otherwise specified on individual house type 'Elevation' drawing, through-coloured concrete interlocking roof tiles to BS EN 490:1994. Roof tile profile to be suitable for specified pitch (in accordance with manufacturer's specification).

Installation to be in accordance with BS 5534:2003 and BS 8000-6:1990 on treated 50 x 25mm s.w. battens or size as specified by the manufacturer, on reinforced bituminous felt underlay or similar approved to BS 747, laid to fall to gutters on proprietary licensed manufacturer's prefabricated trussed

rafters (timber sections neither planed or regularised) at pitches as indicated on drawings and maximum 600mm centres to BS 5268-3:2006. Trussed rafter roof to be fully braced with 100 x 25mm s.w. bracing twice nailed to each truss, in accordance with Roof Design by Specialist and Local Authority requirements.

Trusses to be secured to wall plates using proprietary truss clips with nails fixed through each available hole.

Lateral restraint to be provided at rafter and ceiling tie level with 30 x 5mm galvanised m.s. anchor straps fixed to minimum 3 no. trusses and full depth dwangs between trusses at maximum 1200mm or 2000mm spacing (dependent upon house type) to each gable and party wall as indicated on roof layout drawings. Anchors to be turned down 100mm into wall cavity and fixed with 2 no. 12 x 50mm woodscrews into each truss. No nailing will be permitted. Where traditional heating system is fitted, proprietary water tank support systems to be provided with load spread over minimum 3 no. trussed rafter node points as BS 5268: Part 3. 686 x 562mm roof space access hatch on 33 x 9mm battens in trimmed opening to be provided. Hatch to be insulated and fitted with perimeter draught-seal. Wall plates to be 75 x 100mm s.w. anchored by 30 x 5mm galvanised m.s. straps at maximum 1200mm centres. Straps to be fixed to wall with min. 3 no. screws at least one of which must be located within 150mm of the bottom end of the strap. Strap depths to be 1500mm on 3 storey dwellings, 1200mm elsewhere.

Where roof construction features wall plate supported on steel beam, wall plate to be bolted to top flange of beam with M12 4.6 grade bolts at 750mm centres staggered each side of beam web. Wall plates to be bedded to line and level using nails or straps to hold them down in accordance with the design requirements. Wall plates should generally be in lengths of not less than 3m, but shorter lengths should extend over at least 3 trusses. Wall plates should be joined using half-lapped joints at corners and in running lengths. High level ventilation equivalent to 5mm slot to be provided to heads of all mono-pitch roofs. Rafter and ceiling joist sizes to all roofs other than trussed rafter construction to be in accordance with Structural Engineer's Designs. Ventilation to small bay roofs and porches to be to satisfaction of Local Authority. All roofs to porches and hall/cloaks projections at ground floor to be finished in plain tiles to BS EN 490:1994 except where roof pitch is below 35° or where continuous with garage roof. Installation to be as previously described. Fascia's and barge boards to be shaped to profiles in preservative-treated s.w. or preservative-treated MDF as indicated on elevations. Soffit, eaves and verge over-hang dimensions to be as roof plan. Soffit to be 6mm Tacboard or equivalent.

Roof Ventilation

Roof Pitch between 15° and 35°, which has less than a 10m roof span and is not a mono-pitch or lean-to roof:

Fit eaves soffit ventilator which provides the equivalent of a 10mm continuous slot fitted with fly screen mesh.

Roof Pitch over 35° or where roof span exceeds 10m or is a mono-pitch or lean-to roof:

Fit eaves soffit ventilator which provides the equivalent of a 10mm continuous slot fitted with fly screen mesh. Dry ridge to be fitted which incorporates ventilation providing equivalent of 5mm continuous slot with fly screen mesh.

Lean-to or Mono-pitches to be fitted with abutment ventilator providing equivalent of 5mm continuous slot with fly screen mesh.

Room in roof Requirements (Any roof Pitch):

Fit eaves soffit ventilator which provides the equivalent of a 25mm continuous slot with fly screen mesh. Dry ridge to be fitted which incorporates ventilation providing equivalent of 5mm continuous slot with fly screen mesh.

Min 50mm air gap to be maintained above insulation, fitted within the rafter depth.
Fascia's, barge boards and soffits are all white uPVC.

Horizontal Ceilings Fire Resistance/Insulation

Max U-Value of 0.15 W/m²K

For all 2 and 3 storey houses, all steelwork (if applicable) to be encased to provide "short duration" fire protection and where within floor construction to be painted with intumescent paint providing "short duration" fire protection.

On semi-detached and terraced units minimum 50mm thick mineral wool cavity barrier to be provided within the boxed eaves in line with party wall. Mineral wool fire-stop to be provided under roof covering at top of party walls, above and below the sarking felt.

Similar fire stop to the above to be provided over walls between garage and single storey accommodation where wall is to be built up to roof level.

2 storey Dwellings Floors

Intermediate floor construction to achieve Min FD30 fire resistance. (Short Duration)
Achieved utilizing OTF floor cassette comprising of 220/240mm Engineered STEICO Joists with 15mm OSB deck nailed to top with 15mm Gyproc WallBoard finish to underside, all joints taped and filled.
100mm thick mineral wool quilt between joists (10kgm-3).

2 storey Dwellings Ceiling

12.5mm Gyproc Wallboard finish to the underside, all joints taped & filled, with dwangs fitted.
Mineral fibre insulation to roof void laid between trusses.
(REFER TO APPENDIX 2019A-D FOR HOUSE TYPE SPECIFIC THICKNESS)

3-Storey Intermediate floor

Walls and ceilings within the protected stair and corridor enclosure to achieve MIN FD30 fire resistance.
Intermediate floor/ceiling construction to achieve Min FD30 fire resistance. (Short Duration)
Achieved utilizing OTF floor cassette comprising of 220/240mm Engineered STEICO Joists with 15mm OSB deck nailed to top with 15mm Gyproc WallBoard finish to underside, all joints taped and filled.
100mm thick mineral wool quilt between joists (10kgm-3).

3 storey Upper most ceiling

12.5mm Gyproc Wallboard finish to the underside, all joints taped & filled, with dwangs fitted.
Mineral fibre insulation to roof void laid between trusses.
(REFER TO APPENDIX 2019A-D FOR HOUSE TYPE SPECIFIC THICKNESS)
Insulation laid cross ply laid to ensure edges close butted. All habitable areas to achieve a U value of 0.11 W/m²K.

3 storey Stairwells

Protected enclosure separating partitions to be 'short duration' fire resistance & constructed of either 45mm x 95mm CLS C16 stud partitions or 38 x 75mm s.w. stud partitions at 600mm c/c and mid row 45mm x 95mm dwangs with 12.5mm Gyproc Wallboard 10 taped & filled to both sides.

Second floor ceiling & any coomb to the stairwell protected enclosure to be 1 layer of 12.5mm Gyproc FireLine & all other second floor ceilings to be 12.5mm Gyproc Wallboard fixed to the underside of trusses.

Where ground floor plan features a store located below straight-flight staircase, stair soffit to be lined with 1 layer of 15mm Gyproc WallBoard.

Mineral fibre insulation to roof void laid between trusses. (REFER TO APPENDIX 2019A-D FOR HOUSE TYPE SPECIFIC THICKNESS)

Insulation laid cross ply laid to ensure edges close butted. All habitable areas to achieve a U value of 0.11 W/m²K.

Integral Garage Ceiling

Where a garage and accommodation share a common roof void, garage ceiling to be 1 no. layer 15mm Gyproc Wall board with all joints filled and taped, overlaid with 1 layer 140mm Superglass Timber & Rafter Roll 35 and 1 layer 90mm Superglass Timber & Rafter Roll 35 to be lapped fully over top of wall separating garage from accommodation. Intumescent mastic seal to be formed around the perimeter of the garage ceiling to maintain the fire integrity at the wall junction.

Sloping Ceiling Insulation (Room in Roof)

All sloping ceilings to underside of trusses to be 12.5mm Gyproc Wallboard except on any sloping ceiling or coomb to the stairwell protected enclosure which is to be finished in 1 layer of 12.5mm Gyproc FireLine.

Where ceiling soffit follows pitch of roof, roof insulation to be 100mm PUR rigid insulation (TC value) - 0.022W/mK, located in rafter depth underdrawn with 55mm PUR rigid insulation (TC value) - 0.022W/mK with 500 gauge polythene vapour barrier behind double plasterboard ceiling lining. Insulation to be taken down to wall plate to join with insulation in external cavity walls.

Adequate cross ventilation to be achieved by maintaining a 50mm min. air space above insulation.

Flat roof construction to be insulated in order to achieve **U Value of 0.18 W/m²K.**

Dormer wall construction to be insulated in order to achieve a **U value of 0.22 W/m²K.**

DRAINAGE/HEATING/HOT & COLD WATER ETC.

RAINWATER GOODS

All rainwater goods to be in accordance with 2022 Scottish Building Standards Section 3.6 and BS EN 12056-3:2000 and must be provided for all roofs greater than 6m² in area. All downpipes connected directly to storm water sewers, to Local Authority approval. Refer to house type drainage layout for exact position of connections.

All ranges except SOVEREIGN

Polyflow Deep Capacity Gutter 117mm x 75mm –PVCu to discharge into 63mm dia. downpipes (maximum roof area 37m² per outlet).

SANITARY GOODS

All waste fittings to have 75mm deep seal traps and separate connections to s.v.p.'s and to be installed in accordance with BS 5572:1994, BS EN 12056-1:2000 and BS EN 12056-2:2000. Baths and showers on joisted floors to have flexible joint to wall.

Drainage pipe/waste sizes:

WC	-	100mm	Shower	-	38mm
Bath	-	38mm	Bidet	-	38mm
Sink	-	38mm	WM	-	38mm
WHB	-	32mm for runs <1.7m or 40mm for runs <3m.			

Future shower locations to be provided with a drainage connection sealed and terminated below removable plywood panel set into recess at floor level. Where future shower is separate from accessible toilet a duct to external air is to be provided to allow for future mechanical ventilation.

Where necessary, pipes and hot water storage vessels are to be thermally insulated to comply with 2022 Scottish Building Standards Section 6.4. Washing machine and (where applicable) dishwasher spaces to be plumbed-in. All exposed pipework to be boxed-in. All baths and showers to have a thermostatic mixing valve – Boss mix – TMV2.

All WC's and WHB's will be of a water efficient type and be credited with the European Water Label (EWL).

In accordance with Clause 3.27.2 of the Scottish Building Standards.

SOIL & VENT PIPES

110mm diameter uPVC soil and vent pipes to BS EN 12056-1:2000 and BS EN 12056-2:2000.

Soil vent pipe to be formed at head of drain, vented through roof or at eaves and fitted with proprietary cage. Where SVP rises through roof fit tile flashing. SVP to terminate 900mm above or 3000mm away from any opening window.

Soil pipe branch off's within property, which are not beyond the head of the drain, to be formed to rise above highest fitments and be fitted with suitable sized 'Durgo' or similar approved air admittance valve to relevant BBA Certificate. Valve to be located above flood level of highest connected appliance within a ventilated space and with access for maintenance.

Soil pipes passing through habitable rooms or kitchens to be encased in 38mm x 38mm softwood framing faced with 2 no. layers 12.5mm plasterboard with taped and filled joints. Plasterboard to have a MIN overall mass of 15Kg/m². Pipe to be wrapped in MIN 25mm thick sound insulation quilt. Provisions to be made for access to SVP at ground and first floor level. See also 'Fire Resistance'.

FIRE STOP COLLARS

FIRE STOP FS1510 Intumescent Pipe Collars to be provided where fire-resisting walls and floors are perforated by holes for pipes, ducting and flues. Pipes or ductwork passing through integral garages and through upper floors in all 3 storey dwellings to be boxed in with 2 no. layers 12.5mm WallBoard, joints staggered, taped and filled fixed over s.w. framing.

"Short duration" fire resistance to be maintained between floors and attics, where recessed light fittings located in fire ceilings. Light fittings to be fitted with an appropriate fire resistant shroud by manufacturer or contained in boxing formed from 15mm WallBoard on s.w framing.

No penetrations to be made in separating partitions & any service openings to be fitted with intumescent back boxes.

All doors leading off protected enclosure to be FD30s.

HEATING & HOT WATER

Heating system to be wet system radiators heated by gas fired boiler all in accordance with Heating Consultant's drawings and specification and in compliance with 2022 Scottish Building Standards Section 6. Central heating system to be capable of maintaining a temperature of 21 degrees C in at least 1 apartment and 18 degrees C elsewhere, when the outside temperature is -1 degrees C.

Condensing boiler to be Ideal Logic "ES Combi" or equal and approved.

System boiler to be Ideal Logic "Heat" or equal and approved.

MIN SEDBUK 'A' rating of 89.6% Boiler OR MIN SEDBUK 'A' rating of 89.0% Combi Boiler.

Vented copper hot water storage vessel associated with the system should meet the heat loss and heat exchanger requirements in BS 1566: 2002. Range Tribune Cylinders to be fitted – Refer to standard heating designs for exact type & size. Eco Cylinders & Standard Cylinders specified dependent on house type.

Insulation for pipes and HWC to be to the requirements of BS 5422:2009.

Boiler flues located in accordance with Scottish Building Standards, Section 3.20 and as per manufacturer installation instructions.

Edge of fanned draught flue to be MIN 300mm away from center line of any party wall.

Independent time and temperature control of heating and hot water circuits to be provided with a boiler interlock to ensure that the boiler and pump only operate when there is a demand for heat. Zone controls not required for single apartment dwellings. For large dwellings with a floor area over 150m², independent time and temperature control of multiple space heating zones is recommended. Each zone (not exceeding 150m²) should have a room thermostat and a single multi-channel programmer or multiple heating zone programmers.

For hot water systems in large dwellings, more than one hot water circuit each with independent time and temperature control should be provided.

Hot water system (other than a combi boiler) should have controls that will switch off the heat when the water temp required by the occupants has been achieved, and during periods when there is no demand for hot water. On central heating systems the thermostat for the water system to be interconnected with the other controls which are needed to form a boiler interlock.

Controls required for Combi Boilers:

Boiler Controls -	Boiler interlock and automatic bypass valve, all as recommended by boiler manufacturer, delayed start thermostat with enhanced load compensator or weather compensator.
Time control -	7 day programmer for heating system.
Room Temp Control -	TRV's (Fitted to all radiators except bathroom and en-suite) Room thermostat to be fitted, as located on Heating Consultant's drawings.

Controls required for other boiler types:

Boiler Controls -	Boiler interlock and automatic bypass valve, all as recommended by boiler manufacturer, delayed start thermostat with enhanced load compensator or weather compensator.
-------------------	-------------------------------------------------------------------------------------------------------------------------------------------------------------------------

Time control	-	7 day programmer for heating and water system.
Room Temp Control	-	TRV's (Fitted to all radiators except bathroom and en-suite) Room thermostat to be fitted, as located on Heating Consultant's drawings.
Cylinder Control	-	Cylinder thermostat plus 2 port valves or a 3 port valve. Separately controlled circuits to cylinder and radiators with pumped circulation.
Pump Control	-	Pump overrun timing device as required by manufacturer.

Written information should be made available for the use of the occupier on the operation and maintenance of the heating and hot water service system.

A heating, hot water service, ventilating or cooling system in a dwelling should be inspected and commissioned in accordance with manufacturer's instructions to ensure optimum energy efficiency.

In addition to the Scottish Building Standards, gas-fired appliance installations must also comply with the Gas Safety (Installation and Use) Regulations 1998. These regulations require that, amongst others, gas-fired installations are installed by a competent person.

PIPES

All pipes in concealed low level roofs to be fully lagged at carcass stage to include hair felt over joist areas.

Any/All water supply pipes passing through separating floors to be wrapped in 25mm unfaced mineral fibre to prevent passage of noise.

PHOTOVOLTAIC PANELS (PV'S)

In-roof Photovoltaic panels to be installed in accordance with manufacturers drawings and written specification and in full compliance with the 2022 Scottish Building Standard – Section 6 – Energy.

Photovoltaic panels design and installation to comply fully with the 'Microgeneration Certification Scheme' (MSC Standards) MSC001, MIS3002 and MCS012 ECA 'Guide to the Installation of Photovoltaic Systems'.

PV Panels to be black in colour with black frames and MCS Approved. In-roof PV Mounting System to be MCS Approved, BBA Approved. Mounting system to also achieve a MCS012 PASS and a Broof 4 PASS for fire (Panels and Mounting System).

Inverters to be Solis Mini Series Inverter or equal and MCS Approved. Inverter to come with a minimum 10 year Manufacturers guarantee and to be G83/3 or G59-2 Grid Certified.

PV's have been calculated for each house type on a worst case scenario 'North Facing Front Door'. There will be incidents and sites where the inline roof PV's will be reduced or be on a different roof slope, depending on the orientation of the house. Confirmation to be given to the Local Authority Verifier on a case by case basis.

SERVICES

Cold water rising main to enter via insulated sleeve min. 750mm deep.

DRYING SPACES

Outdoor:

Rear garden to provide an area of at least 1.7m of clothes line per apartment.

Indoor:

Designated space for drying to be provided above the bath, within the bathroom. The space is to provide a volume of at least 1m³ and should have no dimension less than 700mm. The space should also allow for at least 1.7m of clothes line per apartment.

The location of the drying space should not restrict access to any other area or appliance within the dwelling, nor obstruct any door swing.

The Bathroom fan to be connected through a humidistat set to activate when the relative humidity is between 50 and 65

VENTILATION

2 and 3 Storey houses:

All habitable rooms (living rooms, dining rooms and bedrooms but not kitchens, bathrooms or utility rooms) to have ventilation openings of minimum 1/30th of floor area, with some part minimum 1.75m above floor level and to be provided with 12000mm² trickle ventilation.

Where habitable rooms ventilate via an adjoining room, e.g. Conservatory, the above requirements must be satisfied between the adjoining rooms and also between the external room and the outside.

Kitchens and bathrooms to be ventilated by mechanical extract operated intermittently and to be provided with 10000mm² trickle ventilation.

Separate WC accommodation to be provided with either ventilation openings of minimum 1/30th of floor area and 10000mm² trickle ventilation or mechanical extract to give 3 air changes per hour and 10000mm² trickle ventilation.

Where the trickle ventilator is ducted to the external air, the area of the trickle ventilator should be double that noted above.

All trickle ventilators to be located Min 1.75m above FFL.

As an alternative to the trickle ventilation provisions listed above, an overall trickle ventilation rate for the dwelling equivalent to 11000mm² per room may be used subject to a minimum provision of 11000mm² in each apartment.

Minimum extract fan ventilation rates in litres per second as follows:

Kitchen	-	60 l/sec or 30 l/sec if incorporated within cooker hood
Bathroom/Shower Rooms	-	15 l/sec (Bathrooms incorporating drying spaces to be fitted with a fan which is connected through a humidistat set to activate when the relative humidity is between 50 and 65%)
W.C. (With no window)	-	6 l/sec (3 air changes per hour)
Utility Room	-	30 l/sec

Where trickle ventilation cannot be easily provided, e.g. to fully internal rooms with external door but no window, fans to be fitted with 15 minute overrun facility and in the case of rooms with no natural light, to be switched with light. Mechanically ventilated internal rooms to be provided with trickle ventilator, as noted above.

Ventilation provision to be strictly in accordance with 2022 Scottish Building Standards Section 3.14 and Section 3 of current CIBSE Guide B2: 2001.

Measures to limit air infiltration to be in line with 'accredited construction details.'

See drawings for fan locations – cooker hood, ceiling or wall mounted.

Unless otherwise described on Layout drawing, ceiling mounted fans to be ducted either through joist zone to external wall or through roof void to eaves soffit (Grille outlets fitted with fly mesh & coloured to match soffit).

All vertical extract ducts to be fitted with condensate traps and weep pipes.

Garages (With floor areas up to 60m²):

Provide natural ventilation via at least 2 No permanent ventilators, each with an opening area of at least 1/3000th of the floor area they serve, positioned to encourage through ventilation with one of the permanent ventilators being not more than 600mm above floor level.

Air Permeability/Tightness Target Value – 5.01

NOTE – AIR TESTS TO BE CARRIED OUT UPON COMPLETION.

EXTERNAL DRAINAGE

All private drains to be in uPVC or vitrified clay with flexible joints and fittings conforming to BS EN765-3-1997 AND BS EN752-4-1998.

Drains passing through walls to be lintolled over to Engineers specification. Drains under building to have 100mm minimum surround of granular fill bedding factor to pipe manufacturer's specification. Manholes, access chambers or rodding eyes to be formed at all changes in direction, as shown on layout drawings. Hand holes to be fitted to base of all Soil stacks and Rainwater downpipes.

All entrance door and driveway channel drains to be connected to surface water drain line.

All pipework below concrete floor to be 110mm dia. uPVC and have double 45° bends or slow radius bend connections at pop up points through ground floor slab.

WATER SERVICES

Cold water rising main to enter via insulated sleeve min. 750mm deep.

ELECTRICAL SERVICES

Electrical layouts are schematic only.

Installation must comply with BS 7671:2018 and Section 4.5 of the Scottish Building Standards.

All sockets in garages to be protected by residual current circuit breakers.

Lighting point to be provided to any space over 2m².

Consumer unit to be sized to suit loadings generated by the property.

Bathroom/shower room lamp holders to be constructed of & shrouded in insulated material.

Electrical fittings in bathroom to be Safety Extra Low Voltage - SELV rated.

Outlets & controls of electrical fixtures and systems to be positioned at least 350mm from any internal corner, projecting wall or similar obstruction and, unless the need for a higher location can be demonstrated, not more than 1.2m above FFL. This would include fixtures such as sockets, switches, fire alarm, call points and timer controls or programmers.

All should be positioned within the following height range:

1/ Light switches should be positioned at a height of between 900mm and 1100mm above FFL.

2/ Standard switched or un switched socket outlets and outlets for other services such as telephone or television should be positioned at least 400mm above FFL. Outlets/fixtures MIN 150mm above projecting surface/obstruction, such as worktops.

Where socket outlets are concealed, such as to the rear of white goods in kitchens, separate switching is to be provided in an accessible position, to allow appliances to be accessibly isolated.

Minimum socket outlets to be provided as follows:

- 8 No per Living room,
- 4 No per Dining room,
- 6 No per Main Bedroom,
- 4 No per other bedroom,
- 8 No per kitchen or if separate kitchen/utility
- 6 per kitchen and 4 per utility, 3 of which to be above worktop level & not serving white goods,
- 2 No within hallways,
- 2 No within landings on each storey.

100% of the fixed light fittings and lamps installed in a dwelling should be low energy type.

CARBON MONOXIDE (CO) DETECTORS

3. CARBON MONOXIDE ALARMS

- 3.1 A Carbon Monoxide Alarms must be installed in all properties where a gas appliance is installed.
- 3.2 A national commodity agreement is in place with **Wolseley UK Ltd**. The product specified in this agreement is the Honeywell Analytics SF450EN CO Detector trade box X-Series XC70-EN-C Carbon Monoxide Alarm battery operated unit or where specified for use in Housing Association units Honeywell Analytics X-Series XC100-EN-C Carbon Monoxide Alarm battery operated unit. No other product or supplier is to be used unless expressly instructed to do so by the Group Procurement department.

Use Honeywell SF450EN battery operated unit, which can be fixed within the property. These are sealed units, which have a life span of six years. The batteries in the units do not require replacing. Each unit carries specific user instructions including details of the helpline if required. Refer to individual house type working drawing for exact position. Also see above for specification of detector for Housing Associations

CO Alarms should be fixed:

- 1-3m horizontally from the appliance on the Ceiling or 150mm vertically down from the ceiling.
- Above the height of any doors.
- Within any room where a concealed flue in a void travels to an outside wall.

Alarms must not be located:

- In an enclosed space i.e. cupboard.
- Directly above a sink.
- Next to a door or window.
- Next to an extract fan or vent.
- In a damp or humid location.
- In the immediate vicinity of a cooking appliance.

CARBON DIOXIDE (CO₂) DETECTORS

Data Carbon Dioxide Detector (1142) to be located within principle bedroom.

A carbon dioxide detector head requires a flow of air over it to operate correctly, therefore, it should not be located in an area that is likely to restrict the free movement of air. Unless otherwise indicated by the manufacturer, a carbon dioxide detector head should not be sited:

- If ceiling mounted, within 300mm of any wall
- If wall mounted, within 150mm of the ceiling or a junction with another wall
- Where it can be obstructed (for example by curtains, blinds or furniture)
- Next to a door or window, or
- Next to an air vent or similar ventilation opening.

Unless otherwise indicated by the manufacturer, a carbon dioxide monitor, with or without an integral detector, should be mounted between 1.4m and 1.6m above floor level. A carbon dioxide detector head (or monitor if integrated) should not be sited within 1m of the expected location of a bed-head.

SMOKE ALARMS & HEAT ALARMS

Every dwelling to be fitted with a Heat Detector to the Kitchen. A dwelling where no storey is more than 200 m², should be provided with 1 or more smoke alarms located in the circulation space (e.g. Hallway) on each storey and 1 or more smoke alarms located within the principle habitable room (e.g. Living Room) with a standby supply to BS 5446: Part 1: 2000 and installed in accordance with the guidance in clause 2.11.2.

The standby power supply for the smoke alarm should take the form of a primary battery, a secondary battery or a capacitor. The capacity of the standby supply should be sufficient to power the smoke alarm when the mains power supply is off for at least 72 hours while giving a visual warning of mains power supply being off. There should remain sufficient capacity to provide a warning of smoke for a further 4 minutes. An audible warning should be given at least once every minute where the capacity of the standby power supply falls below the recommended standby duration when the mains power supply is on and persist for at least 30 days when the mains power supply is off.

A smoke alarm should be ceiling mounted and located:

In a circulation area which will be used as a route along which to escape.

Not more than 7 m from the door to a living room or kitchen and not more than 3 m from the door to a room intended to be used as sleeping accommodation, the dimensions to be measured horizontally.

Where the circulation area is more than 15 m long, not more than 7.5 m from another smoke alarm on the same storey.

At least 300 mm away from any wall or light fitting, heater or air conditioning outlet.

On a surface which is normally at the ambient temperature of the rest of the room or circulation area in which the smoke alarm is situated.

The above recommendations are broadly in line with the recommendations of BS 5839: Part 6: 2004 for a Grade D Type LD3 system.

Where more than 1 smoke alarm is installed in a dwelling they should be interconnected so that detection of a fire by any one of them operates the alarm signal in all of them.

A smoke alarm should be permanently wired to a circuit. The mains supply to the smoke alarm should take the form of either:

An independent circuit at the dwelling's main distribution board, in which case no other electrical equipment should be connected to this circuit (other than a dedicated monitoring device installed to indicate failure of the mains supply to the smoke alarms); or

A separately electrically protected, regularly used local lighting circuit.

Smoke alarms may be interconnected by 'hard wiring' on a single final circuit.

In order to reduce the frequency of unwanted false alarms, guidance is provided in BS 5839: Part 6: 2004 on the types of sensor most appropriate for the circumstances.

GAS SERVICES

Gas meter to be located in ground mounted uni-box or on surface mounted box enclosure.

Supply of gas to internal fittings to be carried out strictly in accordance with current Gas SAFE regulations. Where passing beneath concrete floor, 22mm gas service pipe to be carried in steel welded duct with emergency cut off valve located outside property. Tracpipe stainless steel semi rigid piping to be utilized in mid terrace construction.

GAS FIRE

If provided, decorative fuel-effect gas appliances should have a provision for combustion air complying with the relevant part of BS 5871-4:2007 and with the appliance manufacturer's specification.

Where balanced flue room heaters are specified they are to be provided with permanent ventilation openings of min. area 450mm² for each kW of appliance input rating exceeding 7kW in accordance with Scottish Building Standards Sections 3.17 - 3.22. Balanced flue outlet to be provided with guard. Position of balanced flue to be not less than 300mm from any opening and in accordance with BS EN 1856-1: 2003 and British Gas guide-lines. Where an extract fan terminal cannot be located more than 300mm away from a balanced flue, an anti-backdraught device must be fitted to the fan terminal. Where flue terminal is within 850mm of a gutter or 450mm of painted eaves, a 750mm long aluminium shield must be fitted to the gutter / eaves underside. Flue to be 300mm min from edge of flue to boundary.

ACCESS TO A DWELLING

Driveway to be MIN 3.3m wide to allow 900mm wide pedestrian route from the parked car to the entrance door.

Access paths and driveways shall be formed in accordance with 1:100 house plot plans.

Access path up to house to be formed 900mm wide at MAX gradient of 1 in 12. MAX cross fall to shed off water is 1 in 40.

Max length of 1 in 12 ramp is 2m. Form level landings between ramp gradients.

Form unobstructed entrance platt 1200x1200, centered on principal entrance door and with a cross fall of not less than 1 in 50.

Entrance door leaf to provide clear opening width of 800mm MIN, with a MIN 300mm unobstructed space adjacent to the leading edge of the door.

Entrance door to incorporate an accessible threshold in accordance with 2022 Scottish Building Standards, Section 4.1.9.

Ground levels to be set level with ramped access and platt levels for a MIN of 300mm before being graded away to existing levels.

External steps to side and rear doors to be formed with Max rise of 170mm and MIN going of 250mm.

ACCESS WITHIN A DWELLING

Access throughout the principal living level to be level and include enhanced apartment, kitchen and shower room or WC with ability to be adapted to shower room at later date.

Doors providing access to the above rooms to have on the principal living level to have an unobstructed area of 1100mm x 800mm space, which is clear of the door swing and orientated in the direction of entry.

Corridors to be 900mm MIN width. This may reduce to 800mm over a Max length of 900mm at an obstruction such as a radiator, except on a wall opposite a doorway.

Doors to have a Min clear opening width as follows to any room, including any apartment, kitchen or sanitary facility:

775mm, where the Min corridor width is 1050mm

800mm, where the Min corridor width is 900mm. (Opening width can be reduced to 775mm where a door is approached head on)

APARTMENTS

Every apartment to be sized to accommodate at least a bed, a wardrobe and a chest of drawers, with all associated activity spaces.

Enhanced apartment: At least one apartment to be located on the principal living level with a Min floor area of 12m² and a length and width of at least 3m. This area cannot have a headroom of less than 1.8m in height and be any portion of space allocated to a kitchen. Also to contain an unobstructed maneuvering space of at least 1.5m x 1.5m or an ellipse of at least 1.4m x 1.8m. Also to have unobstructed access, at least 800mm wide, to the controls of any openable window or any heating appliance and between doors within the apartment. Enhanced apartment also to incorporate an unobstructed area of 1100mm x 800mm space, which is clear of the door swing and orientated in the direction of entry.

Kitchen: Kitchen to accommodate an unobstructed space of at least 1.5m x 1.5m or an ellipse of 1.4m x 1.8m. Kitchen also to incorporate an unobstructed area of 1100mm x 800mm space, which is clear of the door swing and orientated in the direction of entry.

General: All activity spaces to have Min 1.8m headroom over.

ENERGY PERFORMANCE & SUSTAINABILITY

Energy Performance Certificate to be displayed in each property in a prominent and readily accessible location, generally adjacent to the electricity consumer unit in ground floor hall cupboards.

Sustainability Label to be displayed in each property, adjacent to EPC in hall cupboard.

Section 6 energy performance requirements of the 2022 Scottish Building Standards are achieved through increase in insulation to external fabric & PV allocation systems which are incorporated into those house types where the greatest benefit is achieved. (REFER TO APPENDIX 2019A-D FOR HOUSE TYPE SPECIFIC REQUIREMENTS)

SECURITY

All entrance doors & ground floor windows to dwellings to be designed & installed to resist forced entry in accordance with the requirements of Building Scotland Regulations 2022 Standard 4.13.1 by the use of door sets & windows manufactured to meet recognised product standards & defined component performance.

THERMAL BRIDGING

The Y-value calculations of overall thermal bridging for each individual house type are based on the thermally modelled PSI values. (REFER TO APPENDIX 2019E FOR HOUSE TYPE SPECIFIC REQUIREMENTS)

HIGH-SPEED ELECTRONIC COMMUNICATIONS NETWORK

Every house type to be fitted with a BT Open Reach box to provide a High-Speed Electronic Communications Network.

In accordance with Clause 4.14 of the Scottish Building Standards

SANITARY GOODS

- a) Dual flush WC cisterns – An average flush volume of not more than 4.5 litres.
- b) Single flush WC cisterns – A flush volume of not more than 4.5 litres.
- c) Taps serving wash/hand rinse basins – A flow rate of not more than 6 litres per minute.

SOUND TEST

Sound tests to be carried out in accordance with building regulation 5.1.9, table 5.3 for new builds, on plots selected by the local authority building standards. Sound test certificates must accompany plot completion certificate applications.

EXTERNAL FIXED LIGHTING

The accessible entrance of all dwellings shall be provided with a fixed source of automatic external illumination adjacent to the accessible door.

Fixed external lighting shall either be,

- a) Lamp capacity no greater than 100 lamp-watts per light fitting,
- b) All lamps automatically controlled to switch off after the area becomes unoccupied, and
- c) All lamps automatically controlled to switch off when daylight is sufficient.

Or

- a) Lamp efficacy greater than 45 lumens per circuit watt,
- b) All lamps automatically controlled to switch off when daylight is sufficient, and
- c) Light fittings controllable manually by occupants.

CERTIFICATES OF CONSTRUCTION

Electrical, drainage, heating and plumbing installation certificates shall be provided by the relevant contractors upon completion of a plot. Copies of the above certificates must form part of every completion certificate application. Failure to do so can result payment of the building warrant fee discounts.

AIR PERMEABILITY (TIGHTNESS) TESTING

Air testing to be carried out to the satisfaction of the Building Standards Officer and shall generally be at the frequency of 1 in 20 houses or par thereof, to include at least one of each house type on the site.

Air testing to be carried out in accordance with BS EN 13829: 2001 by a suitably qualified person.

Air permeability target – 5.01.

MISCELLANEOUS

Protective works/ Herras fencing to be erected around the perimeter of the site to separate development works from adjacent areas.

Partially complete works shall be kept safe and secure.



Roads and footpaths to kept free from mud, dust and debris adjacent to the site by means of on-site wheel washing facilities and highways vacuum cleaners.

BIN STANCE

Every plot shall be provided with a solid, washable hard-standing surface, large enough to accommodate waste containers and be readily accessible to allow removal. Refer to the house type plot layouts and/ or site plan for location

house type
ROSSDHU END SG

INTERNAL WALL TYPE KEY:

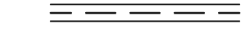
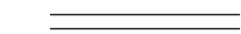
-  38x89mm LOADBEARING WITH 9mm OSB RACKING.
-  38x89mm WITH 9mm OSB RACKING.
-  38x140mm WITH 9mm OSB RACKING.
-  38x89mm LOADBEARING.
-  38x75mm NON LOADBEARING.

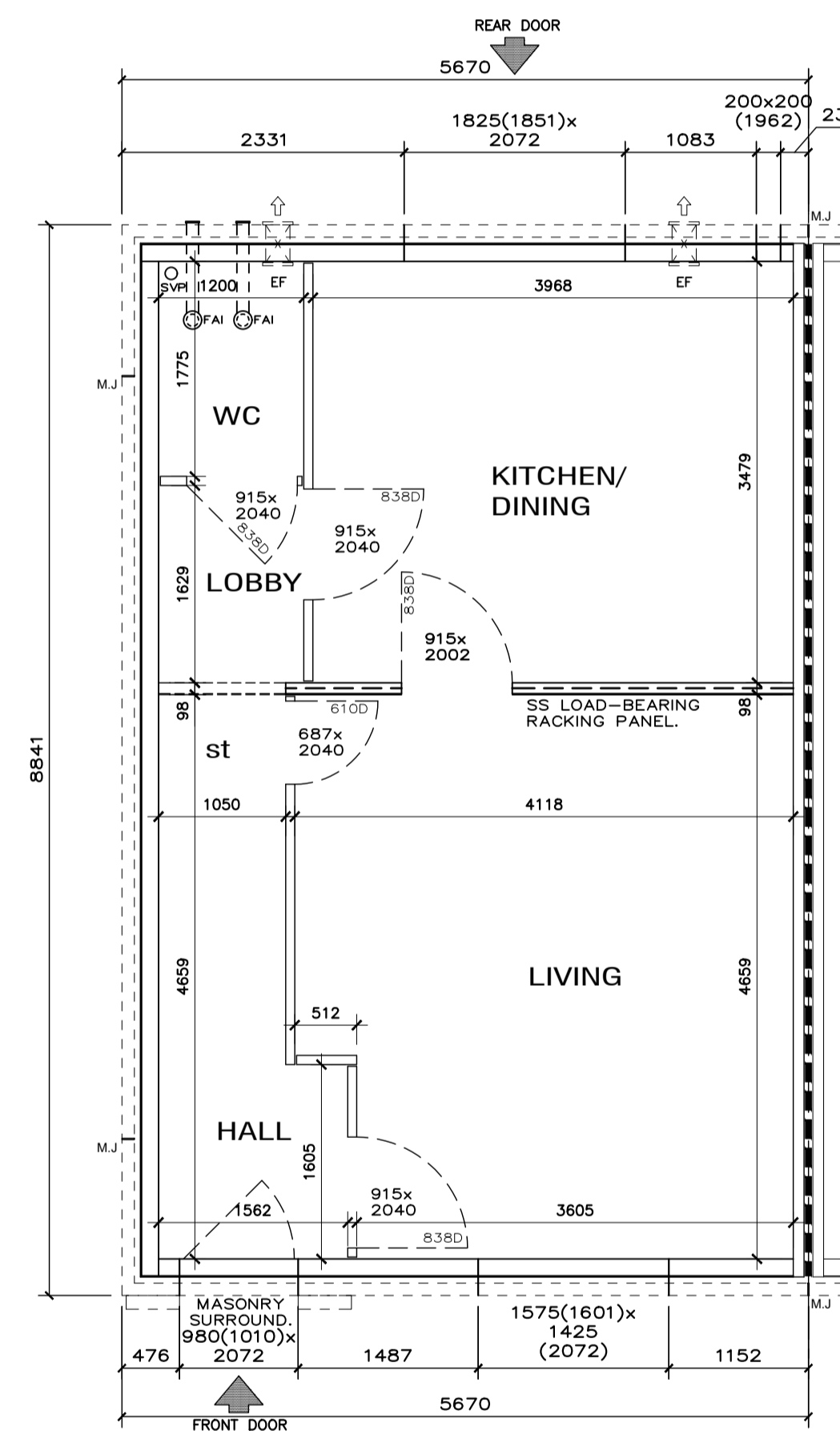

GROUND FLOOR LAYOUT

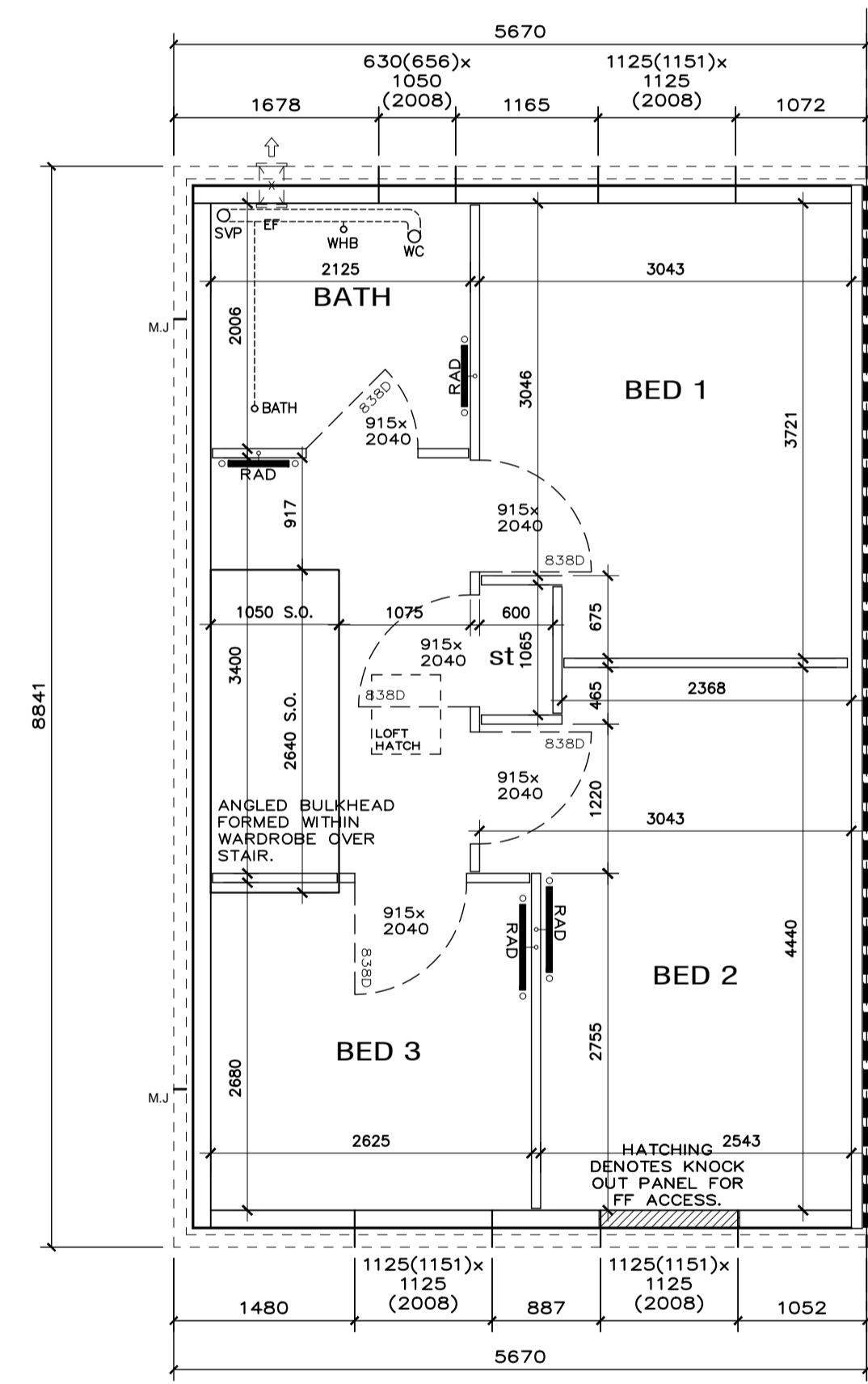

FIRST FLOOR LAYOUT

Amendments:
REFER TO B-STAS D500 DRAWINGS FOR PREVIOUS REVISIONS. GM 17.07.23
UPGRADE TO B-STAS - SA03:
GF - MASONRY SURROUND ADDED AT ENTRANCE DOOR.
FF - BATHROOM EXTRACT FAN NOW WALL MOUNTED.
GF & FF - PANEL RUNS ADDED TO GF EXTERNALS.



Portland Buildings Dunsdale Road
Selkirk Scottish Borders TD7 5EB
Tel. 01750 724940 Fax. 01750 725876

Project: ROSSDHU END SG		
SCOTTISH TYPE APPROVALS BARRATT HOMES - SCOTLAND		
Drawing: TEMPLATE LAYOUT		
Sheet No: Sheet 1 of 1		
Date: JULY 2023	Drawn: GM	Checked: -
Housetype Code: BRHU 02GS SA03		Scale: 1:50
Drawing No: B-STAS (ROSSDHU-SA03-END-SG)TP		Rev: A

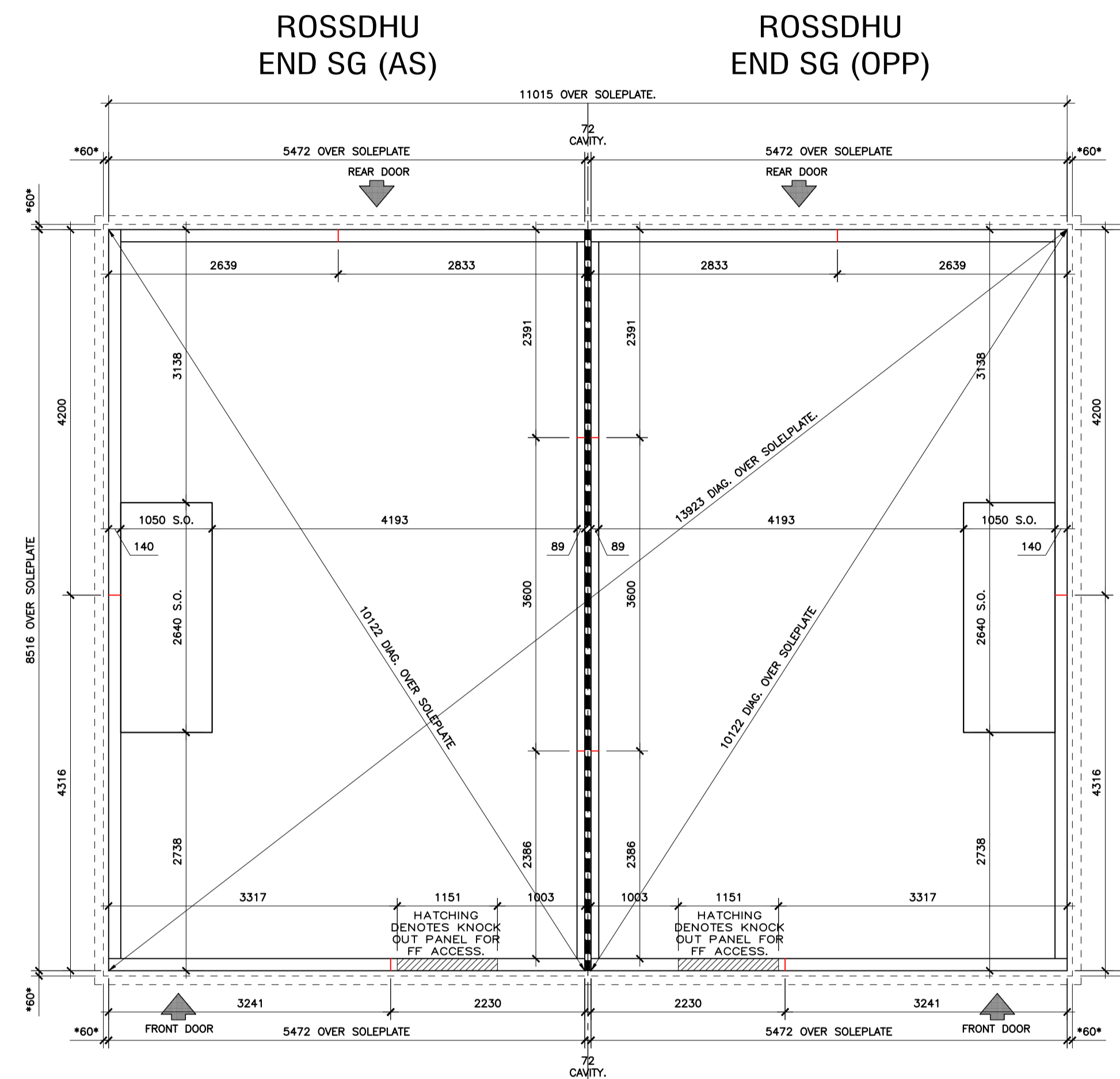
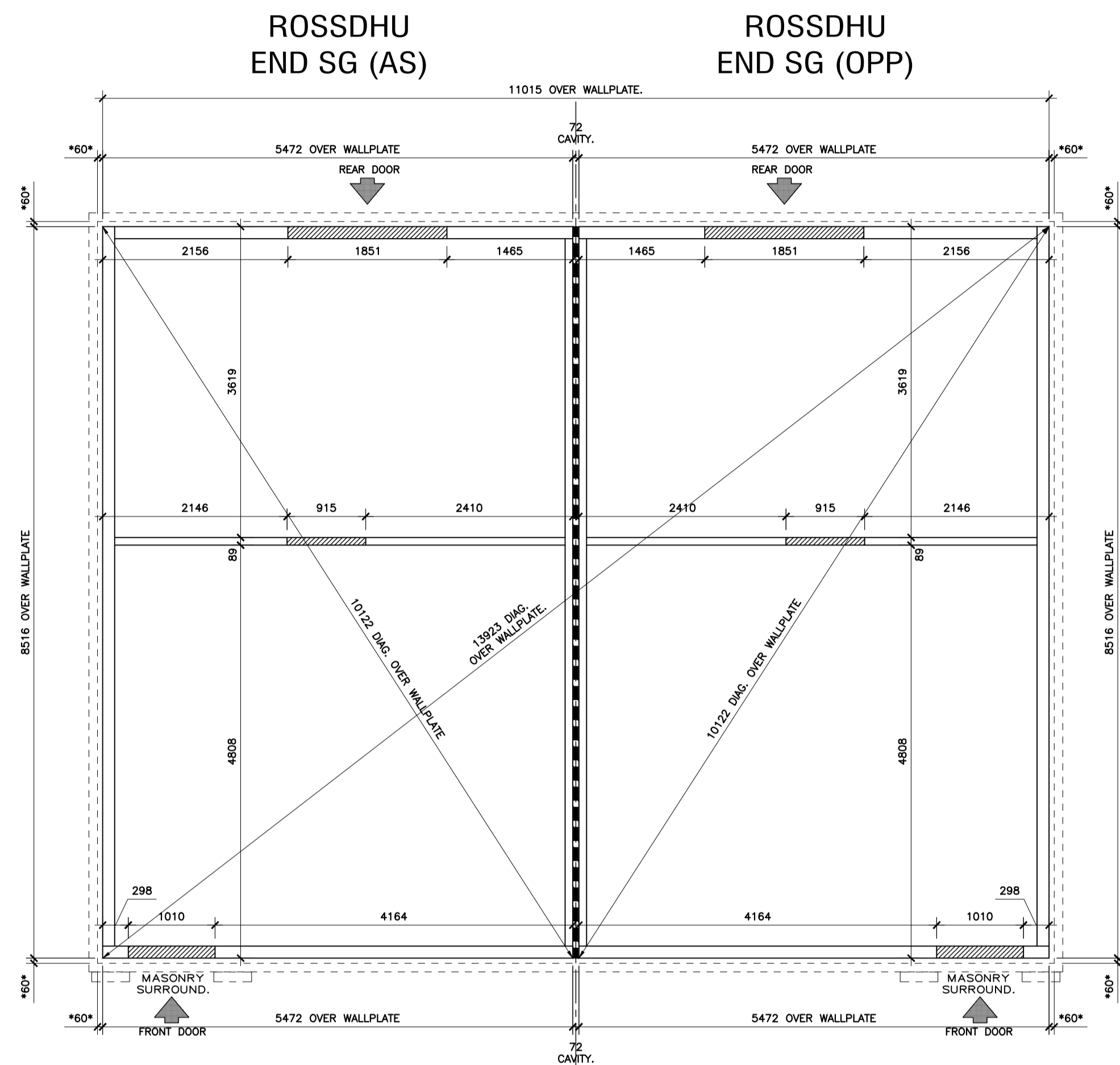

WALLPLATE SETTING OUT LAYOUT

Note: Fix 1No 38mm thick wallplate below all EX, PY & IL panels.

WALLPLATE NOTES:

FOUNDATION SIZES AND DEPTH TO BE CONFIRMED AND DETAILED BY STRUCTURAL ENGINEER CERTIFYING SITE.



FOR EXACT SERVICE DUCT AND DRAINAGE LOCATIONS REFER TO ARCHITECTURAL DRAWINGS.

UNLESS NOTED OTHERWISE ALL EXTERNAL CAVITIES TO BE 60mm WIDE.

ALL WALLPLATES TO BE FIXED AS SPECIFIED IN THE OREGON TIMBER FRAME STANDARD NAILING SCHEDULE.

DASHED LINES DENOTE OUTLINE OF EXTERNAL MASONRY SKIN.

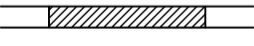
A DPC MUST BE FITTED BETWEEN WALLPLATE AND UNDERBUILDING.

-  DENOTES DOOR OPENING POSITIONS FOR THE AVOIDANCE OF MECHANICAL FIXINGS IN THESE LOCATIONS.
-  DENOTES WHERE 50mm CAVITY WALL INSULATION IS TO BE FITTED.
-  DENOTES DIMENSION FROM INSIDE FACE OF MASONRY OUTER LEAF TO EXTERNAL FACE OF SOLEPLATE.

FF SOLEPLATE SETTING OUT LAYOUT

Note: Fix 1No 38mm thick soleplate below all EX & PY panels.

SOLEPLATE NOTES:

-  DENOTES FF PANEL SPLIT LOCATION. SOLEPLATE/HEADBINDER CUT TO BE LOCATED > 600mm MIN FROM PANEL SPLIT.

Amendments:
REFER TO B-STAS D500 DRAWINGS FOR GM 17.07.23 PREVIOUS REVISIONS.
UPGRADE TO B-STAS - SA03.
GF - MASONRY SURROUND ADDED AT ENTRANCE DOOR.
GF & FF - WALLPLATE/SOLEPLATE LAPS ADDED.



Portland Buildings Dunsdale Road
Selkirk Scottish Borders TD7 5EB
Tel. 01750 724940 Fax. 01750 725876

Project: ROSSDHU SEMI SG		
SCOTTISH TYPE APPROVALS BARRATT HOMES - SCOTLAND		
Drawing: BLOCK WALLPLATE & SOLEPLATE SETTING OUT LAYOUT		
Sheet No: Sheet 1 of 1		
Date: JULY 2023	Drawn: GM	Checked: -
Housetype Code: BRHU 02GS SA03		Scale: 1:50
Drawing No: B-STAS (ROSSDHU-SA03-SEMI-SG)01		Rev: A

house type
ROSSDHU SEMI SG

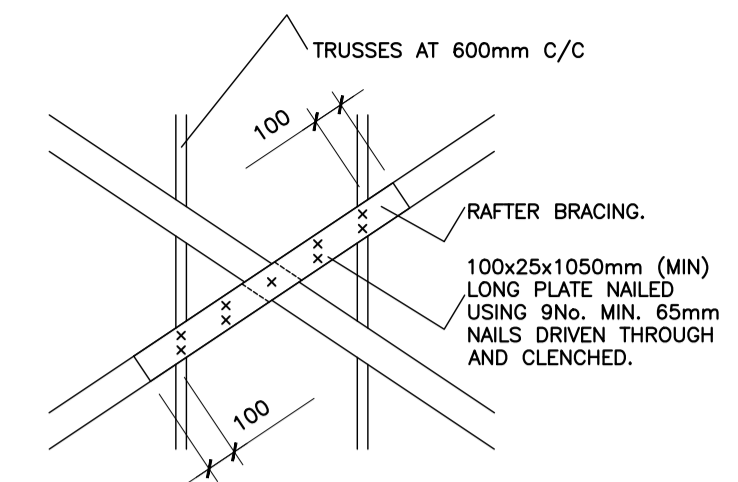

RAFTER BRACING - SPLICE DETAIL
REFER TO LAYOUT PLAN FOR LOCATION OF WHERE RAFTER BRACING CROSSES.

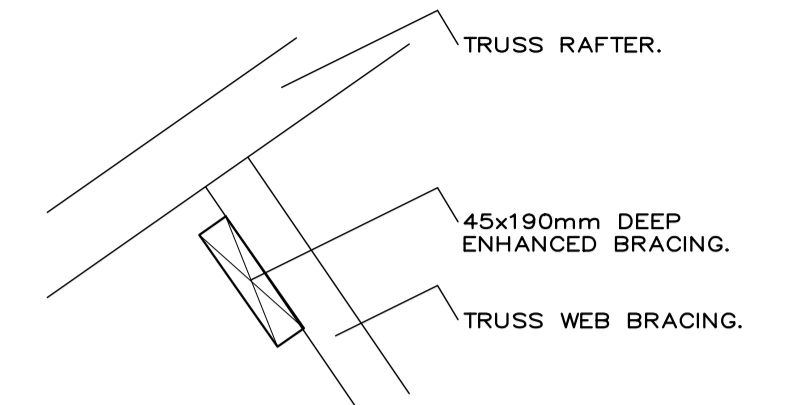

ENHANCED BRACING - FINK TRUSS
SCALE: 1:10.

45x190 ENHANCED BRACING/WIND BRACING TO BE SUITABLY PACKED OUT AT WEBS AT NON STANDARD TRUSSES WHERE WEB POSITIONS VARY.

NOTE: PROVIDE 1No 45x95mm TIMBER TO FACE OF HIP TRUSSES AS SUPPORT TO ENHANCED BRACING. ORIENTATION TO MATCH STANDARD TRUSS WEB BRACING. ENHANCED BRACING TO CONTINUE TO HIP GIRDER TRUSS AS SHOWN ON THE ROOF TRUSS LAYOUT.

● DENOTES LIFTING POINT

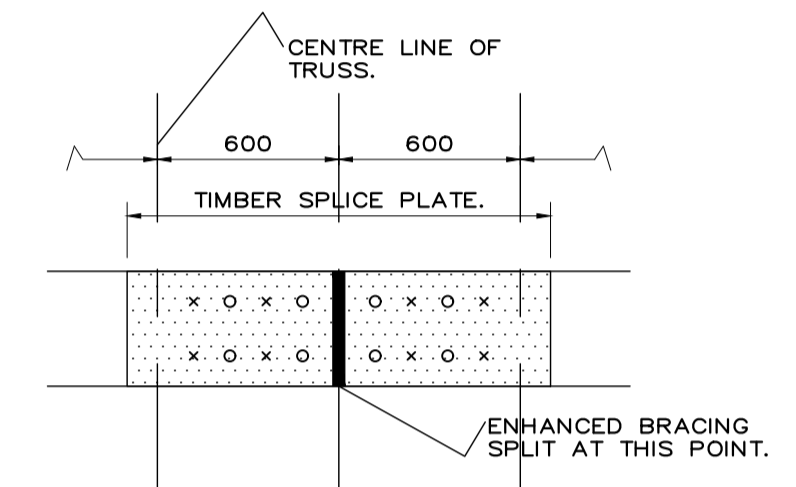

ENHANCED BRACING- SPLICE DETAIL

ENHANCED BRACING SPLICED USING 1No 45x190mm DEEP TIMBER. TO BE LAPPED OVER A MIN. OF TWO TRUSSES.

TIMBER SPLICE PLATE NAILED USING MIN. OF 8No 3.35mm x 90mm LONG GALV. WIRE NAILS EQUALLY SPACED EACH SIDE, DRIVEN THROUGH AND CLENCHED.

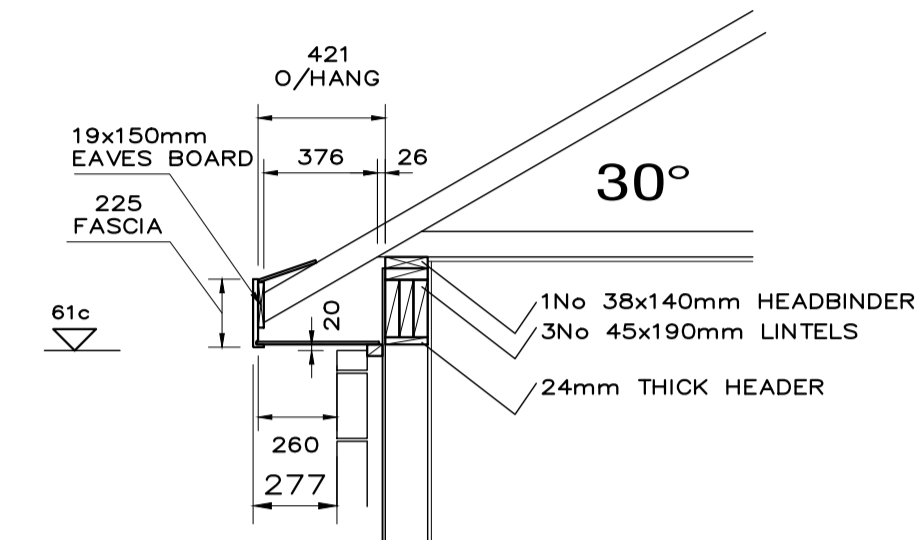

STANDARD EAVES DETAILS

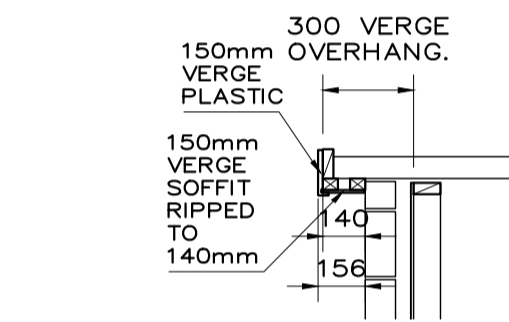

GABLE GABLE VERGE OVERHANG
SCALE 1:25

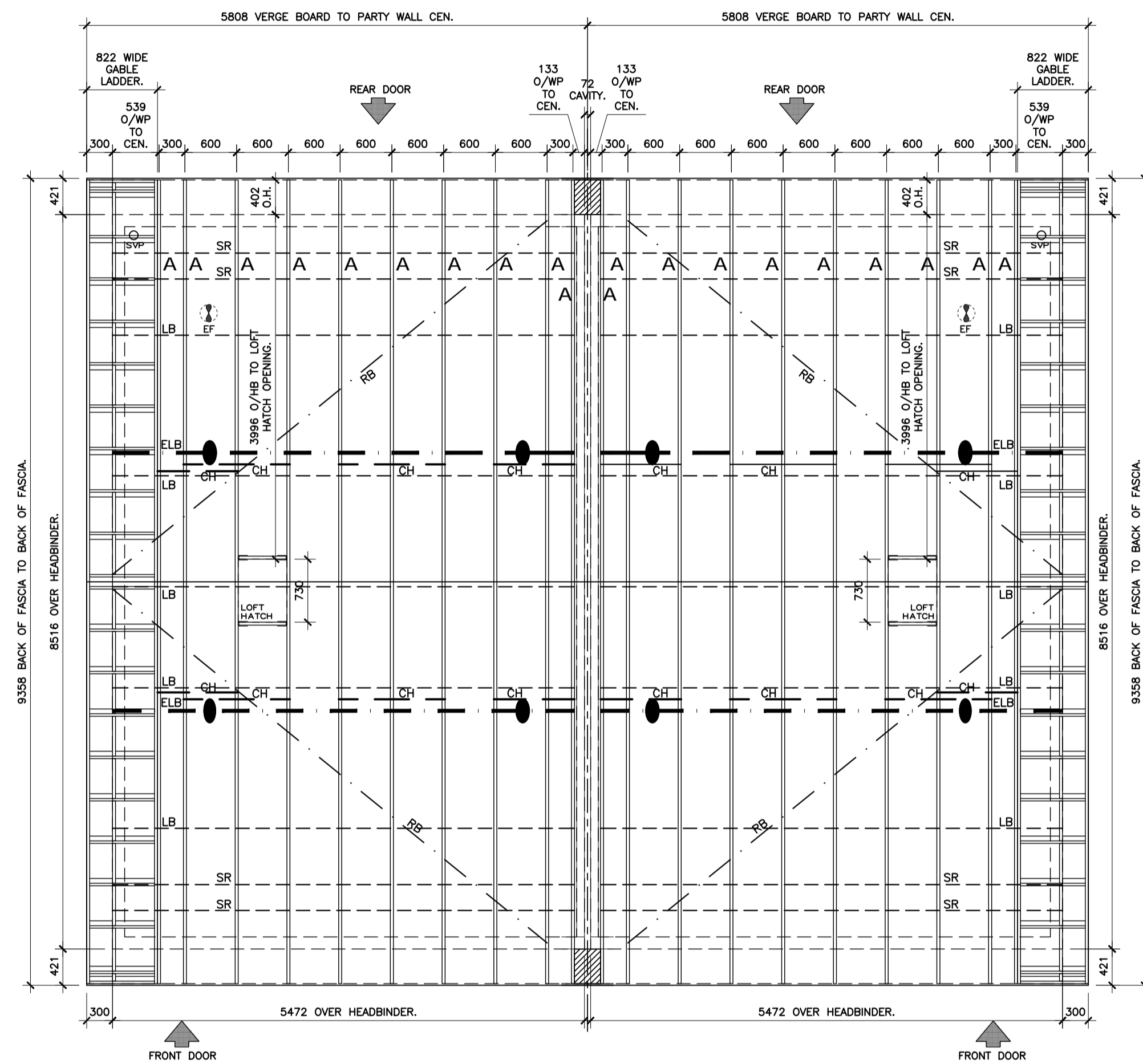

ROOF TRUSS SETTING OUT LAYOUT

Roof Weights:

Main Roof Weight:	1600kg
With 22mm Sarking:	2400kg
With Oxford Matting:	1850kg
With Oxford & Sark:	2650kg

SAFETY RAIL PROVISION: -
WHERE OXFORD MATTING IS TO BE USED, THEN SAFETY RAILS ARE NOT TO BE FITTED.
WHERE TRAD DECK IS TO BE FITTED, THEN SAFETY RAILS ARE TO BE FITTED.

ROOF TRUSS GENERAL:

TRUSSES FIXED TO HEADBINDER USING GALVANISED MILD STEEL TRUSS CLIPS. ALL HOLES IN TRUSS CLIPS TO BE FILLED USING 3.75 x 30mm LONG SHERADISED SQUARE TWIST NAILS.

GABLE LADDERS SECURELY NAILED TO FIRST TRUSS AND TO GABLE PANELS.

100x25mm ROOF BRACING TO BE FIXED AS PER APPENDIX 'A' OF BS 5268. DETAILS ATTACHED TO ERECTION PROCEDURE NOTES.

ALL TIMBERS TREATED AGAINST FUNGAL AND INSECT ATTACK.

INDICATES FIRE BARRIER CLADDING AT PARTY WALL EAVES.

WIND BRACING LEGEND:

- LONGITUDINAL BRACING.
- DIAGONAL RAFTER BRACING.
- ENHANCED BRACING - 45x190mm TIMBER.
- CHEVRON BRACING

DIAGONAL RAFTER BRACING TO BE NAILED TO WALLPLATES OR WHERE LANDING AT GIRDER TRUSS, NAILED TO 38x89x550mm LONG BLOCKS. BLOCKS SECURED TO GIRDERS USING 2No. 87mm LONG LEDGERLOK SCREWS.

Truss Profiles:

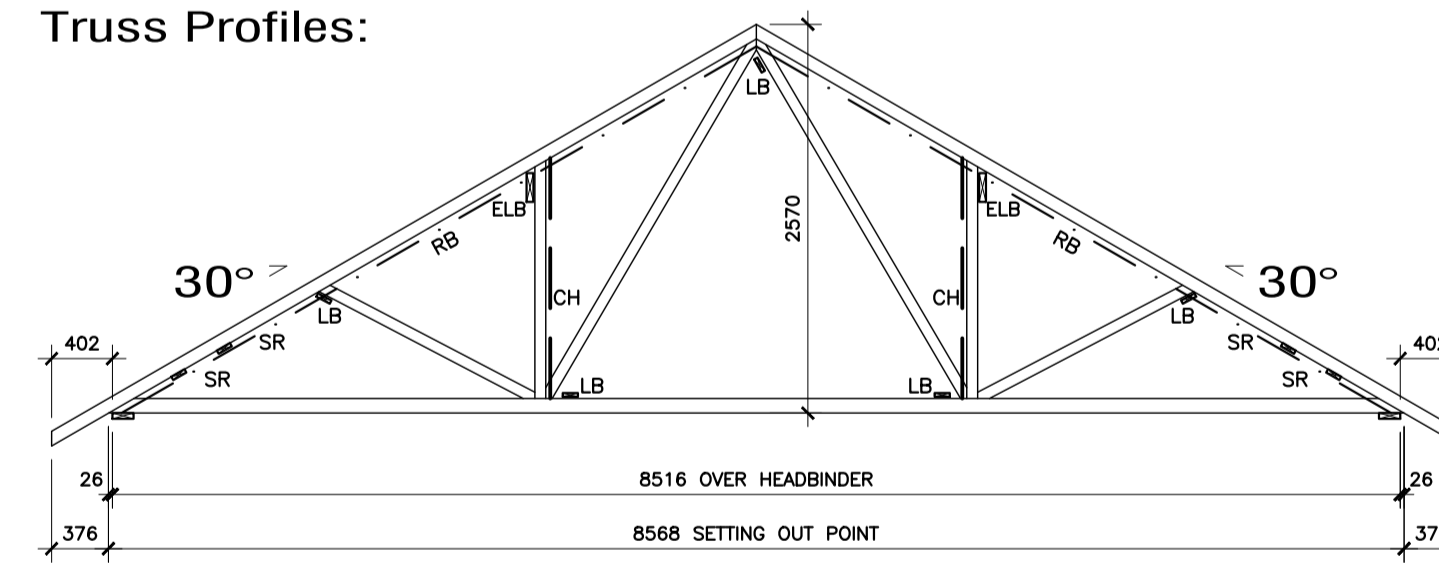

Truss Profile A - 20No

PROFILE MEMBERS SIZES:
35mm x 10-84, BC-97 & WB-72.
TRUSS WEIGHT - 55kg

INCLUDE FOR THE FOLLOWING MATERIAL:
TWO PAIRS 822mm WIDE GABLE LADDERS.
ALL LOOSE MATERIAL REQUIRED TO FORM LOFT HATCH OPENING.
ALL LOOSE CEILING TIE MATERIAL AS SHOWN.

Amendments:
REFER TO B-STAS D500 DRAWINGS FOR PREVIOUS REVISIONS. GM 05.06.23
UPGRADE TO B-STAS - SA03:
ROOF - GABLE TO GABLE VERGE OVERHANG DETAIL INTRODUCED.
TRUSS TOP CHORD REDUCED TO 84mm.

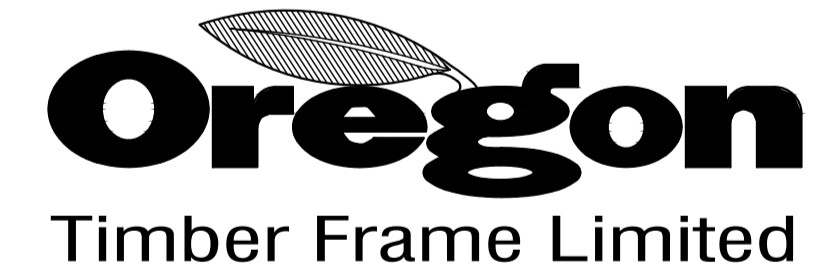

Portland Buildings Dunsdale Road
Selkirk Scottish Borders TD7 5EB
Tel. 01750 724940 Fax. 01750 725876

Project: ROSSDHU SEMI SG		
SCOTTISH TYPE APPROVALS BARRATT HOMES - SCOTLAND		
Drawing: BLOCK ROOF TRUSS LAYOUT & PROFILES		
Sheet No: Sheet 1 of 1		
Date: JULY 2023	Drawn: GM	Checked: -
Housetype Code: BRHU 02GS SA03		Scale: 1:50
Drawing No: B-STAS (ROSSDHU-SA03-SEMI-SG)02		Rev: A

Developer: Barratt West Scotland
 Site: N/A
 Site Layout Ref: N/A

Ver	Housetype	Format	Orientation	Range	Build	Window		Heating	Cylinder	PV (with 0.27 PV panels)	AP	Y	Notes	TER	DER	%	Result	Updated	
						U-Value	Specification												
1	Ardlui	Ground floor			Timber frame	1.4	Scotland TF 2015 - RED	Logic Combi ESP1 35	-	0.54 kWp East/West facing	5.01	0.088	W1 East/West facing	17.01	16.15	-5.06%	Pass	12/10/2020	
1	Ardvorlich	Top floor			Timber frame	1.4	Scotland TF 2015 - RED	Logic Combi ESP1 35	-	0.27 kWp East/West facing	5.01	0.074	W6 East/West facing	16.76	15.76	-5.97%	Pass	13/10/2020	
1	Cashell	Ground Floor			Timber frame	1.4	Scotland TF 2015 - RED	Logic Combi ESP1 35	-	1.08 kWp East/West facing	5.01	0.071	W1 East/West facing	13.28	12.47	-6.10%	Pass	13/10/2020	
1	Endrick	First Floor			Timber frame	1.4	Scotland TF 2015 - RED	Logic Combi ESP1 35	-	0.27 kWp East/West facing	5.01	0.139	W1 East/West facing	14.25	14.15	-0.70%	Pass	13/10/2020	
1	Inverbeg	End Terraced			Timber frame	1.4	Scotland TF 2015 - RED	Logic Combi ESP1 35	-	1.08 kWp East/West facing	5.01	0.078	W1 East/West facing	13.32	12.7	-4.65%	Pass	13/10/2020	
1	Shantron	End Terraced			Timber frame	1.4	Scotland TF 2015 - RED	Logic Combi ESP1 35	-	1.35 kWp East/West facing	5.01	0.075	W1 East/West facing	11.69	11.36	-2.82%	Pass	13/10/2020	
1	Finlas	End Terraced			Timber frame	1.4	Scotland TF 2015 - RED	Logic Combi ESP1 35	-	0.81 kWp East/West facing	5.01	0.073	W1 East/West facing	15.48	15.18	-1.94%	Pass	13/10/2020	
1	Sloy	Detached			Timber frame	1.4	Scotland TF 2015 - BLUE	Logic Heat H15	150	1.89 kWp East/West facing	5.01	0.053	W1 East/West facing	11.44	10.93	-4.46%	Pass	13/10/2020	
1	Cailness	Ground floor			Timber frame	1.4	Scotland TF 2015 - RED	Logic Combi ESP1 35	-	0.81 kWp East/West facing	5.01	0.072	W2 East/West facing	14.3	13.11	-8.32%	Pass	14/10/2020	
1	Cameron	Top floor			Timber frame	1.4	Scotland TF 2015 - RED	Logic Combi ESP1 35	-	0.27 kWp East/West facing	5.01	0.066	W1 East/West facing	16.33	15.33	-6.12%	Pass	14/10/2020	
1	Rossdhu	End Terraced			Timber frame	1.4	Scotland TF 2015 - RED	Logic Combi ESP1 35	-	1.08 kWp East/West facing	5.01	0.076	W1 East/West facing	13.01	12.31	-5.38%	Pass	14/10/2020	

Section 6 - 2015 Specification Summary - Barratt Group Housing
Scotland Timber Frame 2015 Specification - FINAL 16th Feb 2017
Timber Frame Dwellings (NORTH FACING FRONT DOOR) - BLUE SPECIFICATION - ALL DETACHED

Element	Description	Performance
Roofs		
Horizontal Ceiling	Insulated with 300mm Mineral Wool (K-value 0.044)	0.15W/m ² K
Sloping Ceiling	To achieve max. U Value of:	0.15W/m ² K
Sloping Ceiling	Smartroof/I Roof System to achieve max. U Value of	0.15W/m ² K
Flat Roof	Insulated to achieve	0.15W/m ² K
Walls		
External Timber Frame Walls	20mm Render, 100mm Block (Thermal Resistance 0.333m ² k/W), 50mm Cavity, Proctor Reflectashield 0.81, 9mm OSB, 140mm Timber Frame insulated with Mineral Wool (K Value 0.032), 12.50mm Plasterboard - Calculation to be verified via Proctor	0.22W/m ² K
Dormer	Insulated to achieve	0.22W/m ² K
Timber Frame Wall To Garage	12.50mm Gyproc Wallboard 10, 9mm OSB, 140mm Timber Frame insulated with 140mm Mineral Wool (K Value 0.032), 38mm Gyproc Thermaline PIR Insulated Plasterboard	0.22W/m ² K*
Party Walls		
	2 x 89mm Timber Frame, cavity insulated with Superglass TF Party Wall Roll	0.00W/m ² K
Floors		
Solid Ground Floor	140mm Thermal Economics Platinum Ground Floor Insulation	
Timber Floor over Garage (if included within design)	22mm Chipboard, 220mm Timber I-Beam insulated with 220mm Mineral Wool (K-value 0.038), Plasterboard	0.17W/m ² K**
Windows		
	G Factor	U-value
	0.73	1.40W/m ² K
<i>Dwelling to be assessed with Front Door Facing North</i>		
	G Factor	U-value
Keylight	0.76 - Thermal Keylite Window	1.50W/m ² K
	0.71 - Thermo Plus Keylite Window	
Doors		
	U-value	
Front Doors	To achieve max. U Value of:	1.10W/m ² K
Rear Doors	To achieve max. U Value of:	1.10W/m ² K
Heating		
Condensing boiler	Ideal Logic Boilers	
Combi boiler	Ideal Logic Combi ESP1 35	
Secondary Heating		
	None	
Heating Controls		

All Designs	Full Zone Controls.	
	Boiler Interlock & Delayed Start Thermostat	
Hot Water Provision ;		
Range Tribune Cylinders - Refer to standard heating designs for sizing Upon House Type		
Emitter		
Radiators		
Electricity Tariff		
Standard flat rate		
Internal Lighting		
100% Internal Lighting		
Ventilation		
Extract Fans	Standard intermittent extract fans to wet rooms	
Other		
Thermal Bridging	Thermal Economics Assessed Details	
Air Pressure Test	5.01	
Renewables / LZC Technologies		
PV - House Type Specific		
**Shelter Factor Applied to each individual Garage Scenario		
*Shelter Factor Applied to each individual Garage Scenario. U Value quoted does not include Factor. Each Individual Wall calculated with Stewart Milne cold bridging factors - 15% assumed for example		

Section 6 - 2015 Specification Summary - Barratt Group Housing
Scotland Timber Frame 2015 Specification - FINAL 16th Feb 2017
Timber Frame Dwellings (NORTH FACING FRONT DOOR) - GREEN SPECIFICATION - ATTACHED WITH INTEGRAL GARAGE

Element	Description	Performance
Roofs		
Horizontal Ceiling	Insulated with 300mm Mineral Wool (K-value 0.044)	0.15W/m ² K
Sloping Ceiling	To achieve max. U Value of:	0.15W/m ² K
Sloping Ceiling	Smartroof/I Roof System to achieve max. U Value of	0.15W/m ² K
Flat Roof	Insulated to achieve	0.15W/m ² K
Walls		
External Timber Frame Walls	20mm Render, 100mm Block (Thermal Resistance 0.333m ² k/W), 50mm Cavity, Proctor Reflectashield 0.81, 9mm OSB, 140mm Timber Frame insulated with Mineral Wool (K Value 0.032), 12.50mm Plasterboard - Calculation to be verified via Proctor	0.22W/m ² K
Dormer	Insulated to achieve	0.22W/m ² K
Timber Frame Wall To Garage	12.50mm Gyproc Wallboard 10, 9mm OSB, 140mm Timber Frame insulated with 140mm Mineral Wool (K Value 0.032), 38mm Gyproc Thermaline PIR Insulated Plasterboard	0.22W/m ² K*
Party Walls		
	2 x 89mm Timber Frame, cavity insulated with Superglass TF Party Wall Roll	0.00W/m ² K
Floors		
Solid Ground Floor	140mm Thermal Economics Platinum GF Insulation	
Timber Floor over Garage (if included within design)	22mm Chipboard, 220mm Timber I-Beam insulated with 220mm Mineral Wool (K-value 0.038), Plasterboard	0.17W/m ² K**
Windows		
	G Factor	U-value
	0.73	1.40W/m ² K
<i>Dwelling to be assessed with Front Door Facing North</i>		
	G Factor	U-value
Keylight	0.76 - Thermal Keylite Window	1.50W/m ² K
	0.71 - Thermo Plus Keylite Window	
Doors		
		U-value
Front Doors	To achieve max. U Value of:	1.10W/m ² K
Rear Doors	To achieve max. U Value of:	1.10W/m ² K
Heating		
		SEDBUK
Condensing boiler	Ideal Logic Boilers	
Combi boiler	Ideal Logic Combi ESP35	
Secondary Heating		
	None	
Heating Controls		
All Designs	Full Zone Controls.	

	Boiler Interlock & Delayed Start Thermostat	
Hot Water Provision ;		
Range Tribune Cylinders - Refer to standard heating designs for sizing Upon House Type		
Emitter		
Radiators		
Electricity Tariff		
Standard flat rate		
Internal Lighting		
100% Internal Lighting		
Ventilation		
Extract Fans	Standard intermittent extract fans to wet rooms	
Other		
Thermal Bridging	Thermal Economics Assessed Details	
Air Pressure Test	5.01	
Renewables / LZC Technologies		
None		
**Shelter Factor Applied to each individual Garage Scenario		
*Shelter Factor Applied to each individual Garage Scenario. U Value quoted does not include Factor. Each Individual Wall calculated with Stewart Milne cold bridging factors - 15% assumed for example		

Sc

Section 6 - 2015 Specification Summary - Barratt Group Housing
Scotland Timber Frame 2015 Specification - FINAL 16th Feb 2017
Timber Frame Dwellings - RED SPECIFICATION - ATTACHED NO INTEGRAL GARAGE

Element	Description	Performance
Roofs		
Horizontal Ceiling	Insulated with 300mm Mineral Wool (K-value 0.044)	0.15W/m ² K
Sloping Ceiling	To achieve max. U Value of:	0.15W/m ² K
Sloping Ceiling	Smartroof/I Roof System to achieve max. U Value of	0.15W/m ² K
Flat Roof	Insulated to achieve	0.15W/m ² K
Walls		
External Timber Frame Walls	20mm Render, 100mm Block (Thermal Resistance 0.333m ² k/W), 50mm Cavity, Proctor Reflectashield 0.81, 9mm OSB, 140mm Timber Frame insulated with Mineral Wool (K Value 0.032), 12.50mm Plasterboard - Calculation to be verified via Proctor	0.22W/m ² K
Dormer	Insulated to achieve	0.22W/m ² K
Party Walls		
	2 x 89mm Timber Frame, cavity insulated with Superglass TF Party Wall Roll	0.00W/m ² K
Floors		
Solid Ground Floor	120mm Thermal Economics Platinum GF Insulation	
	140mm to Fruin & Luss housetypes (Grd Flr entrance to top floor flats)	
Timber Floor over Car Port (Luss housetype)	28mm Collecta Screedboard, 18mm OSB, 240mm Timber I-Beam insulated with 100mm Mineral Wool (K-value 0.044), 12mm Supalux board, 50mm Kingspan TF70 insulation, Marley boarding on timber battens	0.18W/m ² K (fully exposed floor)
Windows		
	G Factor	U-value
	0.73	1.40W/m ² K
<i>Dwelling to be assessed with Front Door Facing East/west</i>		
	G Factor	U-value
Keylight	0.76 - Thermal Keylite Window	1.50W/m ² K
	0.71 - Thermo Plus Keylite Window	
Doors		
		U-value
Front Doors	To achieve max. U Value of:	1.10W/m ² K
Rear Doors	To achieve max. U Value of:	1.10W/m ² K
Heating		
Condensing boiler	Ideal Logic Boilers	SEDBUK
Combi boiler	Ideal Logic Combi ESP1 35	
Secondary Heating		
	None	
Heating Controls		
All Designs	Full Zone Controls.	

	Boiler Interlock & Delayed Start Thermostat	
Hot Water Provision		
Range Tribune Cylinders - Refer to standard heating designs for sizing Upon House Type		
Emitter		
Radiators		
Electricity Tariff		
Standard flat rate		
Internal Lighting		
100% Internal Lighting		
Ventilation		
Extract Fans	Standard intermittent extract fans to wet rooms	
Other		
Thermal Bridging	Thermal Economics Assessed Details	
Air Pressure Test	5.01	
Renewables / LZC Technologies		
PV - House Type Specific		

SAP Jct	Description	Notes	Ψ_0	F(x)	Correction
E10	Pitched roof, insulation at eaves	30°	0.08025	0.90	0.00000
E10	Pitched roof, insulation at eaves	35°	0.07292	0.90	0.00000
E10	Pitched roof, insulation at eaves	40°	0.67790	0.90	0.00000
E10	Pitched roof, insulation at eaves	45°	0.06408	0.90	0.00000
E10	Pitched roof, insulation at eaves	50°	0.06132	0.90	0.00000
E10	Pitched roof, insulation at eaves	25°	0.09119	0.90	0.00000
E10	Pitched roof, insulation at eaves	47.5°	0.06409	0.90	0.00000
E16	Corner, normal	--	0.02066	1.00	0.00000
E17	Corner, inverted	--	-0.05737	1.00	0.00000
E18	Party wall between dwellings	--	0.10618	0.50	0.00000
E2	Other lintels (including other steel lintels)	Adj. E6	0.21281	1.00	0.00684
E2	Other lintels (including other steel lintels)	Adj. E10 (35°)	0.14176	1.00	0.07292
E3	Sill	--	0.09109	1.00	0.00000
E4	Jamb	Standard reveal	0.04676	1.00	0.00000
E4	Jamb	Bay window	-0.00604	1.00	-0.05737
E5	Ground floor, normal	Garage wall	0.34769	0.92	0.00000
E5	Ground floor, normal	Red ThermaEdge	0.21317	1.00	0.00000
E5	Ground floor, normal	Blue ThermaEdge	0.23451	1.00	0.00000
E6	Intermediate floor within a dwelling	--	0.00684	1.00	0.00000
E7	Intermediate floor between dwellings	--	0.10532	0.50	0.00000
E20	Exposed floor, normal	--	0.05122	0.92	0.00000
E12	Gable, insulation at ceiling	--	0.06632	0.90	0.00000
P1	Party wall to ground floor	Red	0.08122	0.50	0.00000
P1	Party wall to ground floor	Blue	0.08377	0.50	0.00000

Ψ

0.072
0.066
0.610
0.058
0.055
0.082
0.058
0.021
-0.057
0.053
0.206
0.069
0.091
0.047
0.05133
0.320
0.213
0.235
0.007
0.053
0.047
0.060
0.041
0.042

	Set value - please do not input data into this field
	Shelter Factor - please adjust as required
	Calculated result - dependent on shelter factor

SAP Jct	Description	Notes	F(x)	Ψ	fRsi
E10	Pitched roof, insulation at eaves	30°	0.90	0.072	0.82
E10	Pitched roof, insulation at eaves	35°	0.90	0.065	0.82
E10	Pitched roof, insulation at eaves	40°	0.90	0.060	0.83
E10	Pitched roof, insulation at eaves	45°	0.90	0.057	0.83
E10	Pitched roof, insulation at eaves	50°	0.90	0.055	0.84
E10	Pitched roof, insulation at eaves	25°	0.90	0.082	0.81
E10	Pitched roof, insulation at eaves	47.5°	0.90	0.057	0.83
E16	Corner, normal	--	1.00	0.022	0.89
E17	Corner, inverted	--	1.00	-0.063	0.96
E18	Party wall between dwellings	--	0.50	0.053	0.86
E2	Other lintels (including other steel lintels)	Adj. E6	1.00	0.146	0.61
E2	Other lintels (including other steel lintels)	Adj. E10 (35°)	1.00	0.071	0.81
E3	Sill	--	1.00	0.091	0.68
E4	Jamb	Standard reveal	1.00	0.045	0.80
E4	Jamb	Bay window	1.00	-0.012	0.83
E5	Ground floor, normal	Red	1.00	0.147	0.81
E5	Ground floor, normal	Garage wall	0.92	0.320	0.66
E5	Ground floor, normal	Blue	1.00	0.165	0.81
E5	Ground floor, normal	Red ThermaEdge	1.00	0.212	0.76
E5	Ground floor, normal	Blue ThermaEdge	1.00	0.233	0.76
E6	Intermediate floor within a dwelling	--	1.00	0.064	0.87
E7	Intermediate floor between dwellings	--	0.50	0.053	0.86
E20	Exposed floor, normal	--	0.92	0.047	0.85
E12	Gable, insulation at ceiling	--	0.90	0.059	0.84
P1	Party wall to ground floor	Red	0.50	0.041	
P1	Party wall to ground floor	Blue	0.50	0.042	

	Set value - please do not input data into this field
	Shelter Factor - please adjust as required
	Calculated result - dependent on shelter factor

House Type Working Drawings -

01: Planning	Rev A
02: Elevations	Rev A
03: Ground Floor Plan	Rev B
04: First Floor Plan	Rev C
05: Foundation Plan	Rev A
06: Roof Plan	Rev A
07: Section A-A	Rev A
08: Kitchen Plan	Rev -
09: Future Shower Room	Rev -
10: Joist Layout	Rev -

Detailed Revision Description

<u>Rev</u>	<u>Description</u>	<u>Date</u>
DS00	Initial Issue	11.01.19
DS01	Bath in bathroom rotated 180 degrees and shelf changed into full height bulk head	29.06.22
DS02	Front door position revised Addition of dimensions All notes standardised across range Correction of drawing title boxes Removal of weep vents at front and rear soffit level and side roof rake Bathroom shower arrangement revised	12.04.23
SA03	First Floor Bathroom layout revised 9mm OSB added to loadbearing wall Stairwell opening set at standard 1050mm wide	24.07.23
SA04	Single excavation for incoming services	1.12.23

* Denotes updated drawing sheet.

WALL LEGEND	
309	External wall External render coating on blockwork outer leaf, Min. 50mm clear cavity, 9mm OSB, 140mm stud, 9mm OSB, 12.5mm plasterboard.
300	External wall External render coating on blockwork outer leaf, min. 50mm clear cavity, 9mm OSB, 140mm stud, 12.5mm plasterboard.
248	External garage wall Block/Brick/Stone outer leaf, min. 50mm clear cavity, 9mm OSB, 89mm stud, 12.5mm plasterboard.
250	Party wall 12.5mm plasterboard, 19mm plank, 89mm stud, 9mm OSB, 54mm clear cavity, 9mm OSB, 89mm stud, 19mm plank, 12.5mm plasterboard.
250	Party wall 12.5mm plasterboard, 25mm service zone, 12.5mm plasterboard, 19mm plank, 89mm stud, 9mm OSB, 54mm clear cavity, 9mm OSB, 89mm stud, 19mm plank, 12.5mm plasterboard, 25mm service zone, 12.5mm plasterboard.
158	Internal garage wall 38mm insulated plasterboard, 9mm OSB, 140mm studs, 9mm OSB, 12.5mm plasterboard.
149	Internal garage wall 38mm insulated plasterboard, 140mm studs, 9mm OSB, 12.5mm plasterboard.
107	Internal LB wall 12.5mm plasterboard, 9mm OSB, 89mm studs, 9mm OSB, 12.5mm plasterboard. (structural walls - refer to drawings for acoustic insulation)
98	Internal LB wall 12.5mm plasterboard, 9mm OSB, 89mm studs, 12.5mm plasterboard. (structural walls - refer to drawings for acoustic insulation)
93	Internal racking wall 12.5mm plasterboard, 9mm OSB, 75mm studs, 9mm OSB, 12.5mm plasterboard. (structural walls - refer to drawings for acoustic insulation)
84	Internal racking wall 12.5mm plasterboard, 75mm studs, 9mm OSB, 12.5mm plasterboard. (structural walls - refer to drawings for acoustic insulation)
89	Internal LB wall 12.5mm plasterboard, 89mm studs, 12.5mm plasterboard. (structural walls - refer to drawings for acoustic insulation)
75	Internal wall 12.5mm plasterboard, 38 x 75mm cls, 12.5mm plasterboard. (non structural walls - refer to drawings for acoustic insulation)

TOTAL FLOOR AREA : 85.00m² / 916sqft

Sales Name: **ROSSDHU**
 House Type Code: **BRHU 02GS**
 Spec: **RSL** Drawing No: **2020/STAS/DATA**
 Drawn: **GDT** Checked: **AB** Scale: **1:50@A3** Date: **Jan 19**

DATA SHEET

Rev: 03
 Description: Updates shown on Data Sheet

Date: July 23



Thermal Spec:
BLUE (det)

WARNING TO HOUSE PURCHASERS:
 Buyers are warned that this is a working drawing and the contents of this drawing may be subject to change during the progress of the build process. The layout, form, content and dimensions specified are included for general guidance only. The finishes or features shown may alter in respect of individual properties. Whilst we make every effort to ensure our drawings are up to date there may be from time to time be an unavoidable delay in updating these due to changes in regulations and/or re-planning. Purchasers are advised to check with the Sales Department for the most up to date version of this drawing. The drawings of this drawing do not constitute a contract, part of any contract or warranty unless specifically incorporated into the contract. They should not be relied upon for the purposes of entering into a contract to purchase any property.

Thermal Spec:
BLUE (det)



Date:
April 23

Description:
Refer to Data Sheet

Rev:
A

WARNING TO HOUSE-PURCHASERS.
Buyers are warned that this is a working drawing and the contents of this drawing may be subject to change during the design process. The layout, dimensions, materials and finishes shown may differ from those shown in the final drawings. Whilst we make every effort to ensure our drawings are up to date there may be changes in regulations and/or re-planning. Purchasers are advised to check with the Sales Adviser whether any alterations have been made to this drawing. The contents of this drawing do not constitute a contract, part of any contract or warranty unless otherwise stated. The drawing is to be used for information only and is not to be relied upon for the purposes of entering into a contract to purchase any property.

Sales Name: **ROSSDHU**
House Type Code: **BRHU 02GS**
Spec: **RSL** Drawing No: **2020/STAS6/02**
Drawn: **GDT** Checked: **AB** Scale: **1:100@A3** Date: **Jan 19**

TOTAL FLOOR AREA : 85.00m² / 916sqft

ELEVATIONS

Indicative PV panel position
Final position to be confirmed
depending on orientation
of house.



FRONT ELEVATION

WALL FINISH KEY:

- Thru-coloured Render
- Facing Stone or Facing Brick, refer to Dev. finishes schedule.
- Engineer designed bed joint reinforcement in Rendered external masonry: Below and above window/door openings and to project 600mm beyond openings either side.

Weep Vents at 900mm intervals as per standard details.
Weep vents provided above openings should be spaced at max. 900mm intervals. Each opening should have at least two weep vents per opening.

- 5mm continuous ridge ventilation
- Engineer designed bed joint reinforcement in first two courses of external masonry below and above window/door openings and to project 600mm beyond openings either side.
- Precast Concrete surround to project 15mm beyond render
- Mono-pitch roof to be ventilated at high level with either proprietary apex ventilation or vent tiles.
- Cavity tray & code 4 lead flashing to all abutment
- Storming or similar Precast Concrete roof to bay
- 225mm facing stone or facing brick plinth
- * Toughened & clear
- ** Toughened & obscure

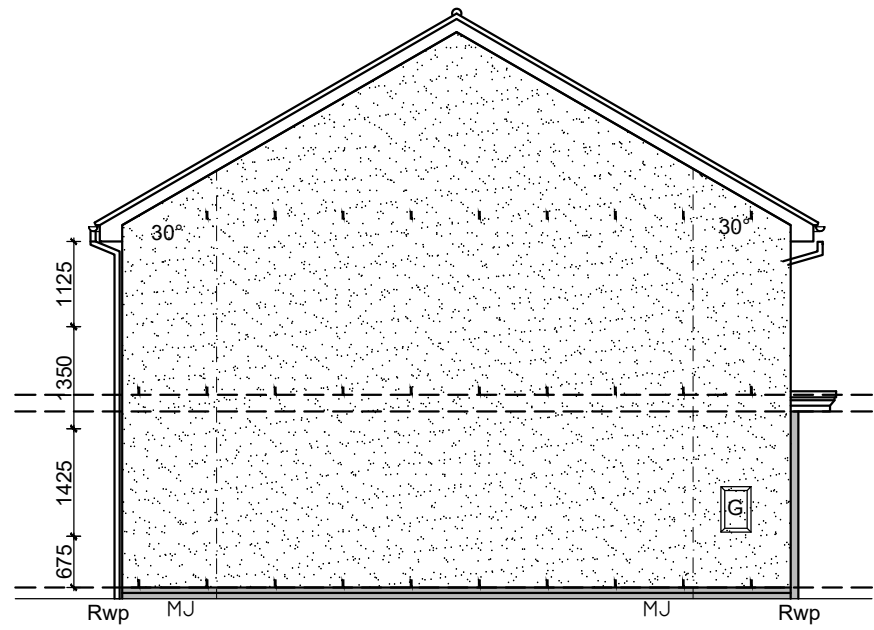

SIDE ELEVATION

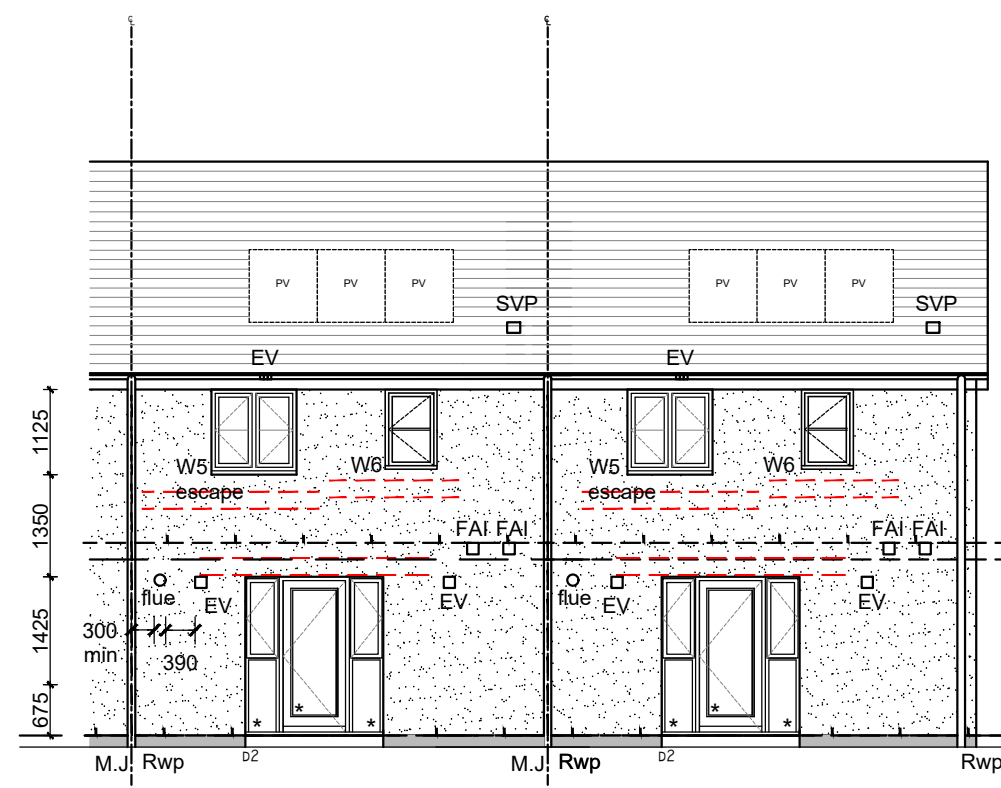

REAR ELEVATION

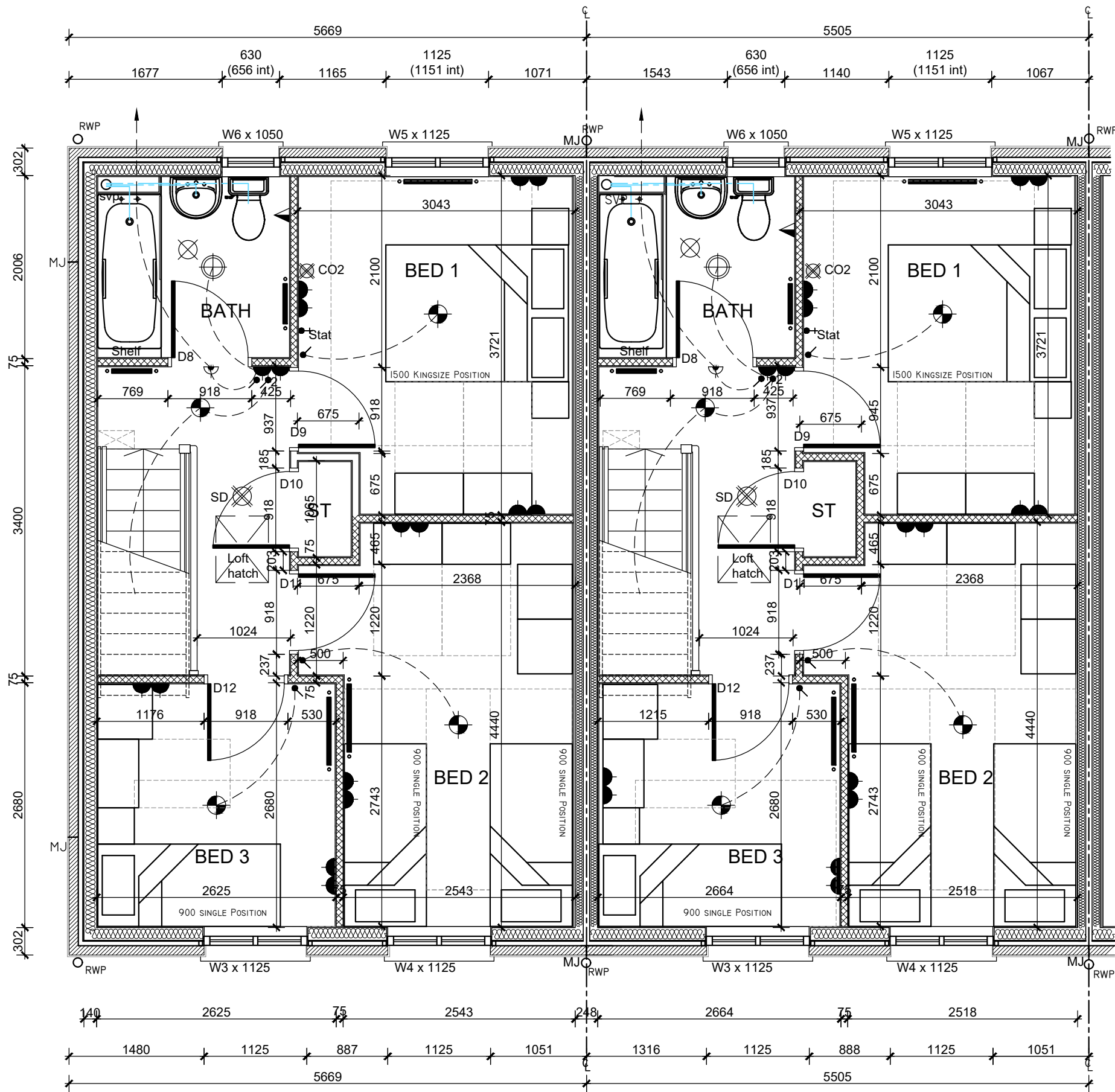

M.J indicates movement joint locations, to be hidden behind RWDP where possible

Bathroom to be ventilated by humidistat extract vent providing intermittent ventilation of 15l/s min

Bathroom extract vent to be ducted through attic to soffit.

E.S.1 Extract isolated separately from light.

Stair balustrade to be min 900mm above F.F.L

SVP boxed with 2x12.5mm plasterboard. Void to be packed with Fibreglass quilt insulation

RWP positions may differ from that shown. For actual location refer to site specific drainage layout

WALL KEY:

- Blockwork as Engineer's Specification
- Timber stud partitions to achieve min 43dB sound reduction
- Movement joint

ELECTRICAL SYMBOLS KEY

Setting out of all socket outlets and system controls to be in accordance with DET/09/01/08

- EF Ceiling mounted extract fan
- EF Wall mounted extract fan
- SDi Ionized Smoke Detector
- SDo Optical Smoke Detector
- CO Carbon Monoxide Detector. To wall - located above the height of any door or window min 150mm from ceiling. To Ceiling - located min 300mm from any wall & Within 3.0m of Appliance
- CO2 Carbon Dioxide Detector with integrated monitor (2015 Regs only). Wall mounted only (1600mm FFL); Located min. 300mm from any ceiling/wall junction. Located min. 500mm on plan from any door or window.
- HD Heat Detector
- Shaver socket outlet
- im Immersion switch
- G Gas point
- Double socket outlet
- Pendant light fitting with Low Energy bulb
- Batten light fitting with Low Energy bulb
- IPX4 batten light fitting with Low Energy bulb
- Wall mounted light fitting with Low Energy bulb
- PIR Accessible Entrance light also switched via Passive Infrared Detector
- TV TV point
- BT Telephone point
- CU Consumer unit
- Lightswitch
- Lightswitch - 2 way
- Extract Fan isolator switch with 'FAN' label/symbol @ H.L. centred above door
- Thermostat
- Doorbell to handle side, mounted on frame, level with handle
- Door Chime
- Media Plate 2No. Twin 13Amp Sw Skts + 1No. TV point & Tel point
- BTOR BT Open Reach Location - Refer to Trade Specification if to be utilised on site.

DOOR SCHEDULE

Door Ref	Door Size (widthxheight)	Door weight(kg)	Lintel Ref (weight kg)	Fire Door
D8	838 x 1981mm	18.0	N/A	No
D9	838 x 1981mm	18.0	N/A	No
D10	838 x 1981mm	18.0	N/A	No
D11	838 x 1981mm	18.0	N/A	No
D12	838 x 1981mm	18.0	N/A	No

WINDOW SCHEDULE

Window Ref	Struct opening (widthxheight)	Lintel Ref (weight kg)	Fire Escape
W3	1151 x 1125mm	N/A	Yes
W4	1151 x 1125mm	N/A	Yes
W5	1151 x 1125mm	N/A	Yes
W6	630 x 1050mm	N/A	No

OTHER OPENINGS

L3	Bed 1 Roof timber beam	152x89x16 UB
----	------------------------	--------------

TOTAL FLOOR AREA : 85.00m² / 916sqft

Sales Name: **ROSSDHU**

House Type Code: **BRHU 02GS**

Spec: **RSL** Drawing No: 2020/STAS/04

Drawn: **GDT** Checked: **AB** Scale: 1:50@A3 Date: Jan 19

FIRST FLOOR PLAN

Description: Refer to Data Sheet

Rev: C

Date: April 23

Thermal Spec:

BLUE (det)

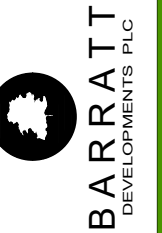

WARNING TO HOUSE-PURCHASERS:
Buyers are warned that this is a working drawing and the contents of this drawing may be amended during the project. The drawings are for your information only. The drawings and details shown are not to be used for construction purposes. The finishes or features shown may alter in respect of individual properties. Whilst we make every effort to ensure our drawings are up to date there may be changes in time to time due to an unavoidable delay in updating these due to changes in regulations and/or re-planning. Purchasers are advised to check with the Sales Adviser whether any alterations have been made to this drawing. The contents of this drawing do not constitute a contract, part of any contract or warranty unless otherwise stated. The drawings are to be used for the purposes of entering into a contract to purchase any property.

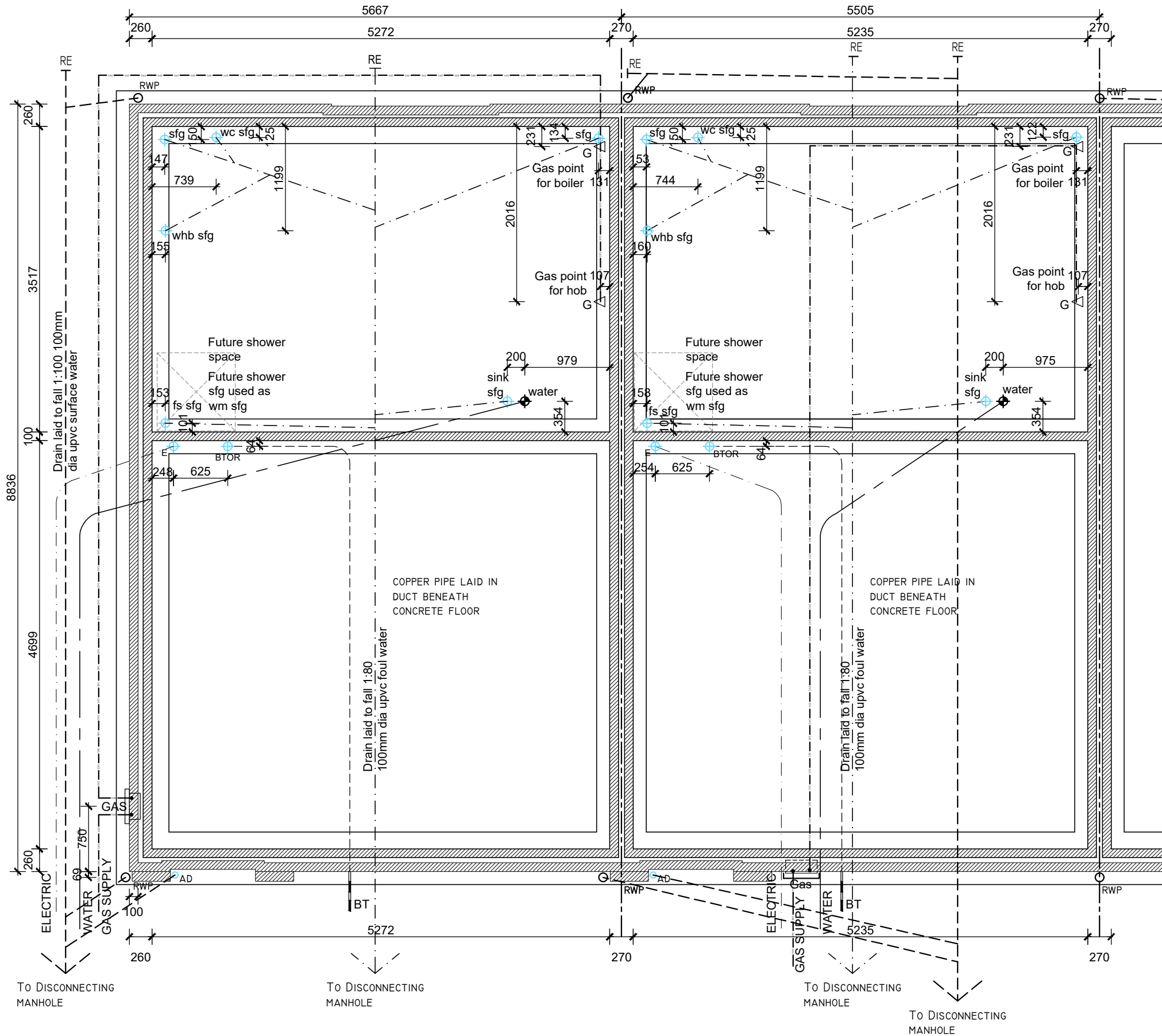

FOUNDATIONS
 Foundations are shown as 600mm wide strip. Width and type of foundation may vary dependant upon ground conditions. For plot specific foundation design, refer to structural engineers information. Depth of foundation to satisfy NHBC requirements and to be agreed on site with BCO.

RWP positions may differ from that shown. For actual location refer to site specific drainage layout

WALL KEY:
 [Hatched Box] Blockwork as Engineer's Specification

SERVICE DUCTS
 Electric supply ducted only where below floor slab. BT ducted from connection to entry point on foundation plan.

TOTAL FLOOR AREA : 85.00m² / 916sqft

Sales Name: **ROSSDHU**

House Type Code: **BRHU 02GS**

Spec: **RSL** Drawing No: 2020/STAS/05

Drawn: **GDT** Checked: **AB** Scale: 1:50@A3 Date: Jan 19

FOUNDATION PLAN

Rev: A Description: Refer to Data Sheet Date: April 23

Thermal Spec:

BLUE (det)



WARNING TO HOUSE-PURCHASERS.
 Buyers are warned that this is a working drawing and the contents of this drawing may be subject to change during the agreed period of the project. The layout, for the purposes of this drawing, is intended to provide a guide only. The finishes or features shown may alter in respect of individual properties. Whilst we make every effort to ensure our drawings are up to date there may be changes in time to time to be an unavoidable delay in updating these due to changes in regulations and/or re-planning. Purchasers are advised to check with the Sales Adviser whether any alterations have been made to this drawing. The contents of this drawing do not constitute a contract, part of any contract or warranty unless otherwise stated. The drawing is provided for the purposes of entering into a contract to purchase any property.

ACTIVITY SPACES

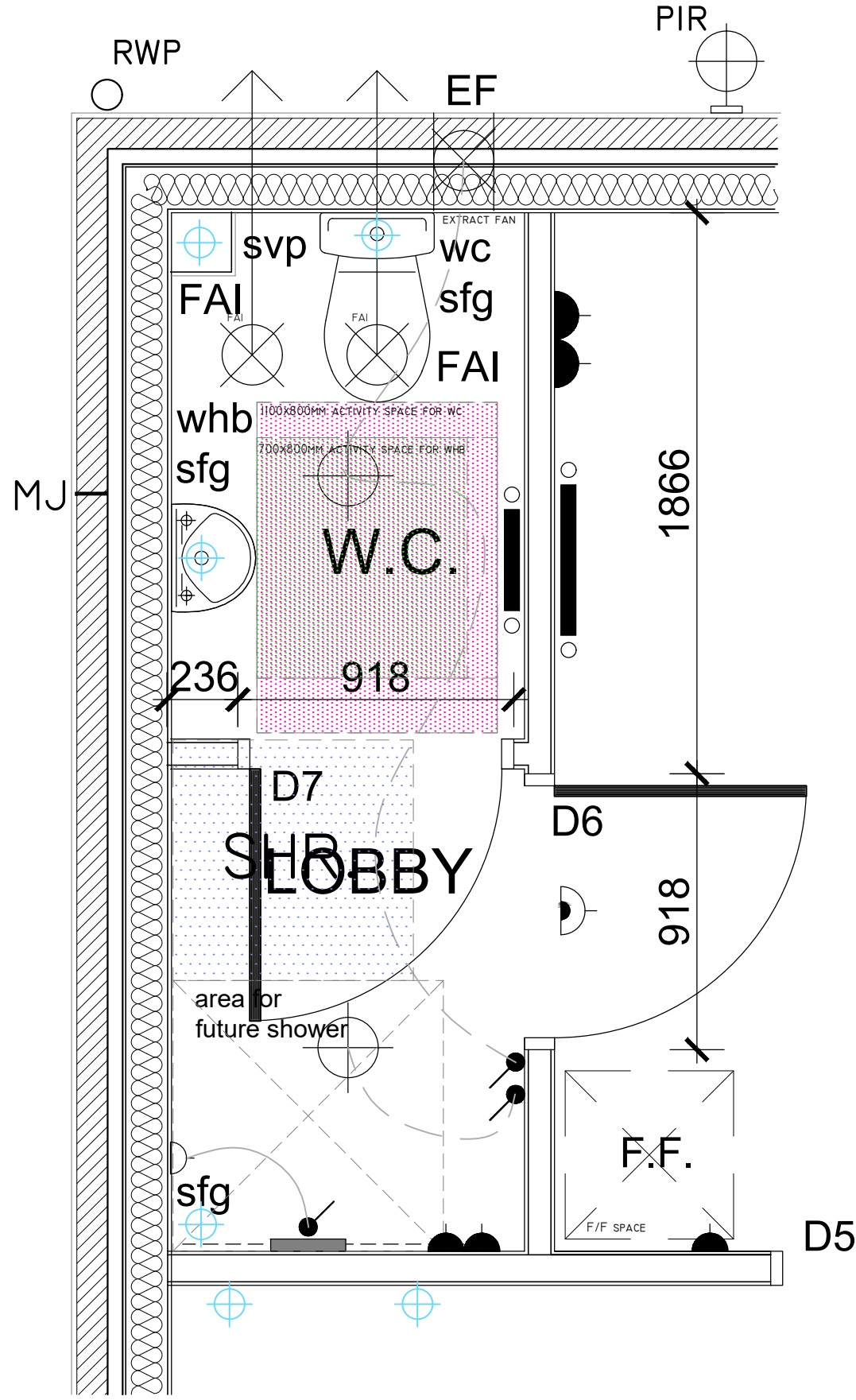
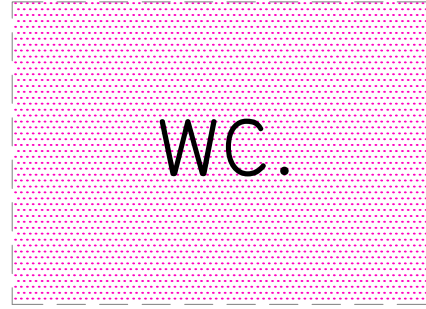
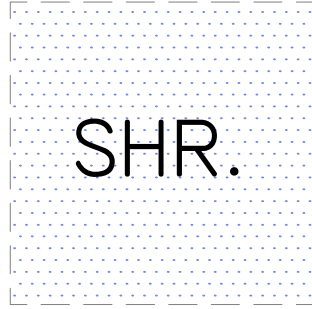

TOTAL FLOOR AREA : 85.00m² / 916sqft

Sales Name: **ROSSDHU**

House Type Code: **BRHU 02GS**

Spec: **RSL** Drawing No: 2020/STAS/09

Drawn: **GDT** Checked: **AB** Scale: 1:20@A3 Date: Jan 19

FUTURE SHOWER ROOM

Rev: -
Description: Refer to Data Sheet
Date: April 23

Thermal Spec:

BLUE (det)



BARRATT
DEVELOPMENTS PLC

WARNING TO HOUSE-PURCHASERS.
Buyers are warned that this is a working drawing and the contents of this drawing may be subject to change during the design and construction process. The layout, dimensions and details shown are for information only and are not intended to be used for construction. The finishes or features shown may alter in respect of individual properties. Whilst we make every effort to ensure our drawings are up to date there may be changes in regulations and/or re-planning. Purchasers are advised to check with the Sales Adviser whether any alterations have been made to this drawing. The contents of this drawing do not constitute a contract, part of any contract or warranty unless the drawing is specifically referred to in a contract. Purchasers are advised to rely upon the purposes of entering into a contract to purchase any property.

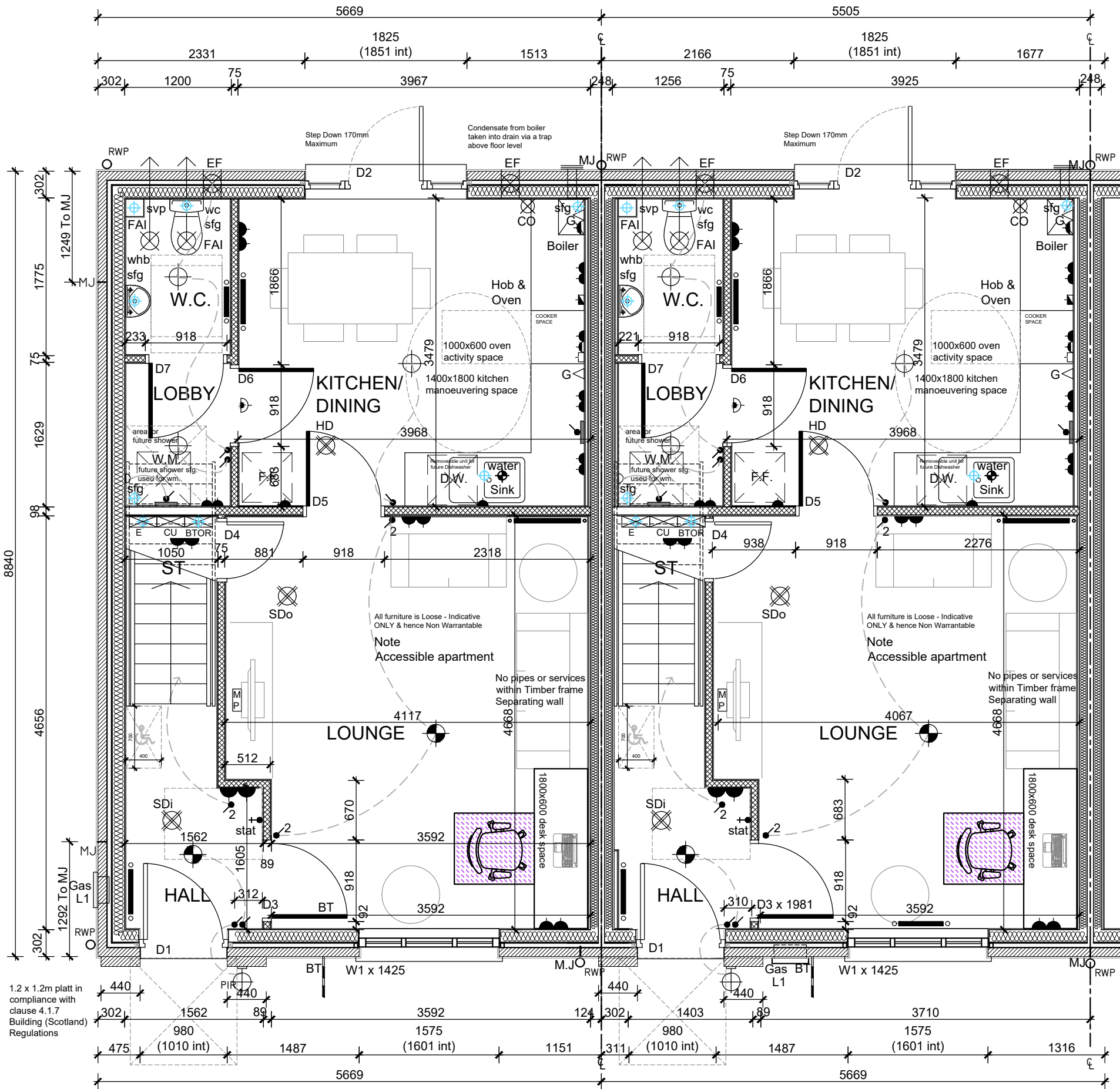

1.2 x 1.2m platt in compliance with clause 4.1.7 Building (Scotland) Regulations

M.J indicates movement joint locations, to be hidden behind RWDP where possible

Kitchen to be ventilated by Cooker Hood extract vent providing intermittent ventilation of 30l/s minimum

Additional sealed floor gully to be provided in the lobby for future installation of shower

15mm Gyproc plasterboard to underside of stairs for fire protection

SVP boxed with 2x12.5mm plasterboard. Void to be packed with Fibreglass quilt insulation

Boiler flue outlet to be min 300mm from door/window opening

Acoustic insulation provided within timber stud partitions between wet rooms and living areas, and between bedrooms

RWP positions may differ from that shown. For actual location refer to site specific drainage layout

Level threshold to Standard Detail

Level approach to front entrance max gradient 1:20 min 1200mm width

WALL KEY:

- Blockwork as Engineer's Specification
- Timber stud partitions to achieve min 43dB sound reduction
- Movement joint

ELECTRICAL SYMBOLS KEY

- Setting out of all socket outlets and system controls to be in accordance with DET/09/01/08
- EF Ceiling mounted extract fan
 - EF Wall mounted extract fan
 - SDi Ionized Smoke Detector
 - SDo Optical Smoke Detector
 - CO Carbon Monoxide Detector. To wall - located above the height of any door or window min 150mm from ceiling. To Ceiling - located min 300mm from any wall & Within 3.0m of Appliance
 - CO2 Carbon Dioxide Detector with integrated monitor (2015 Regs only). Wall mounted only (1600mm FFL); Located min. 300mm from any ceiling/wall junction. Located min. 500mm on plan from any door or window.
 - HD Heat Detector
 - Shaver socket outlet
 - im Immersion switch
 - G Gas point
 - Double socket outlet
 - Pendant light fitting with Low Energy bulb
 - Batten light fitting with Low Energy bulb
 - IPX4 batten light fitting with Low Energy bulb
 - Wall mounted light fitting with Low Energy bulb
 - PIR Accessible Entrance light also switched via Passive Infrared Detector
 - TV TV point
 - BT Telephone point
 - CU Consumer unit
 - Lightswitch
 - Lightswitch - 2 way
 - Extract Fan isolator switch with 'FAN' label/symbol @ H.L. centred above door
 - Thermostat
 - Doorbell to handle side, mounted on frame, level with handle
 - Door Chime
 - Media Plate 2No. Twin 13Amp Sw Skts + 1No. TV point & Tel point
 - BTOR BT Open Reach Location - Refer to Trade Specification if to be utilised on site.

DOOR SCHEDULE				
Door Ref	Door Size (widthxheight)	Door weight(kg)	Lintel Ref (weight kg)	Fire Door
D1	915 x 2100mm	52	Refer to IG schedule	No
D2	1825 x 2100mm	---	Refer to IG schedule	No
D3	838 x 1981mm	18.0	---	No
D4	610 x 1981mm	16.0	---	FD30
D5	838 x 1981mm	18.0	---	No
D6	838 x 1981mm	18.0	---	No
D7	838 x 1981mm	18.0	---	No

WINDOW SCHEDULE			
Window Ref	Struct opening (widthxheight)	Lintel Ref (weight kg)	Fire Escape
W1	1601 x 1425mm	L7/50 1950 (9.57)	No

OTHER OPENINGS		
L1	Meter box	METER BOX LINTEL 0750 (2.21)

TOTAL FLOOR AREA : 85.00m² / 916sqft

Thermal Spec: **BLUE (det)**

BARRATT DEVELOPMENTS PLC

GROUND FLOOR PLAN

Date: April 23

Description: Refer to Data Sheet

Rev: B

WARNING TO HOUSE-PURCHASERS: Buyers are warned that this is a working drawing and the contents of this drawing may be subject to change without notice. The drawings are prepared for your information only and are not to be used for construction purposes. The finishes or features shown may alter in respect of individual properties. Whilst we make every effort to ensure our drawings are up to date there may be changes in time to time due to an unavoidable delay in updating these due to changes in regulations and/or re-planning. Purchasers are advised to check with the Sales Adviser whether any alterations have been made to this drawing. The contents of this drawing do not constitute a contract, part of any contract or warranty unless the drawing is specifically referred to in a contract or warranty. The contents of this drawing are entered upon for the purposes of entering into a contract to purchase any property.

Sales Name: **ROSSDHU**

House Type Code: **BRHU 02GS**

Spec: **RSL** Drawing No: 2020/STAS/03

Drawn: **GDT** Checked: **AB** Scale: 1:50@A3 Date: Jan 19

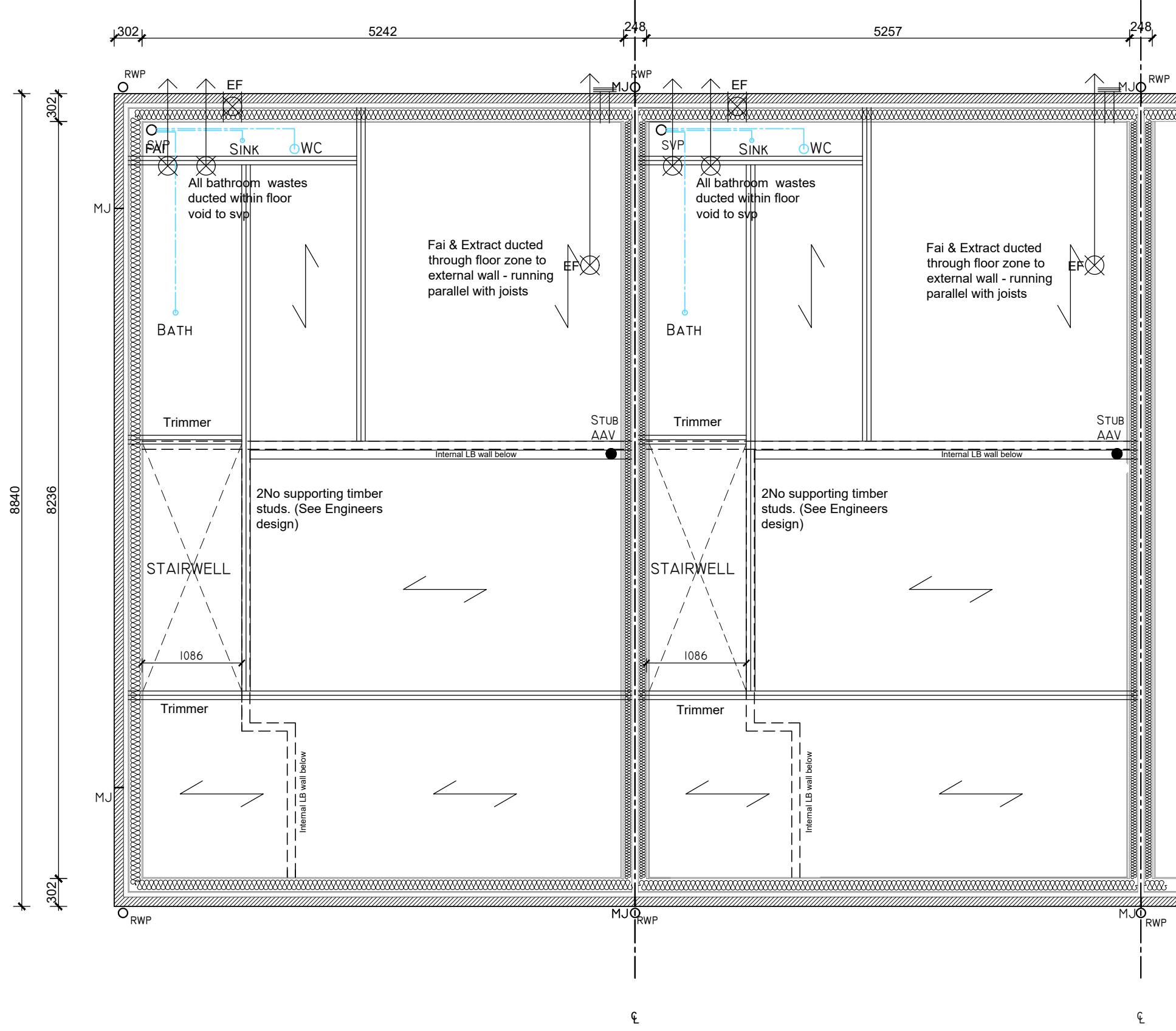

TOTAL FLOOR AREA : 85.00m² / 916sqft

Sales Name: **ROSSDHU**

House Type Code: **BRHU 02GS**

Spec: **RSL** Drawing No: **2020/STAS/10**

Drawn: **GDT** Checked: **AB** Scale: **1:50@A3** Date:

JOIST PLAN

Rev: -
Description: Refer to Data Sheet

Date: April 23

Thermal Spec:

BLUE (det)



BARRATT
DEVELOPMENTS PLC

WARNING TO HOUSE-PURCHASERS.
Buyers are warned that this is a working drawing and the contents of this drawing may be subject to change during the design and construction process. The layout, form and dimensions shown may alter in respect of individual properties. The finishes or features shown may alter in respect of individual properties. Whilst we make every effort to ensure our drawings are up to date there may be changes in time to time due to an unavoidable delay in updating these drawings. The contents of this drawing do not constitute a contract, part of any contract or warranty unless otherwise stated. The drawing is provided for information only and should not be relied upon for the purposes of entering into a contract to purchase any property.

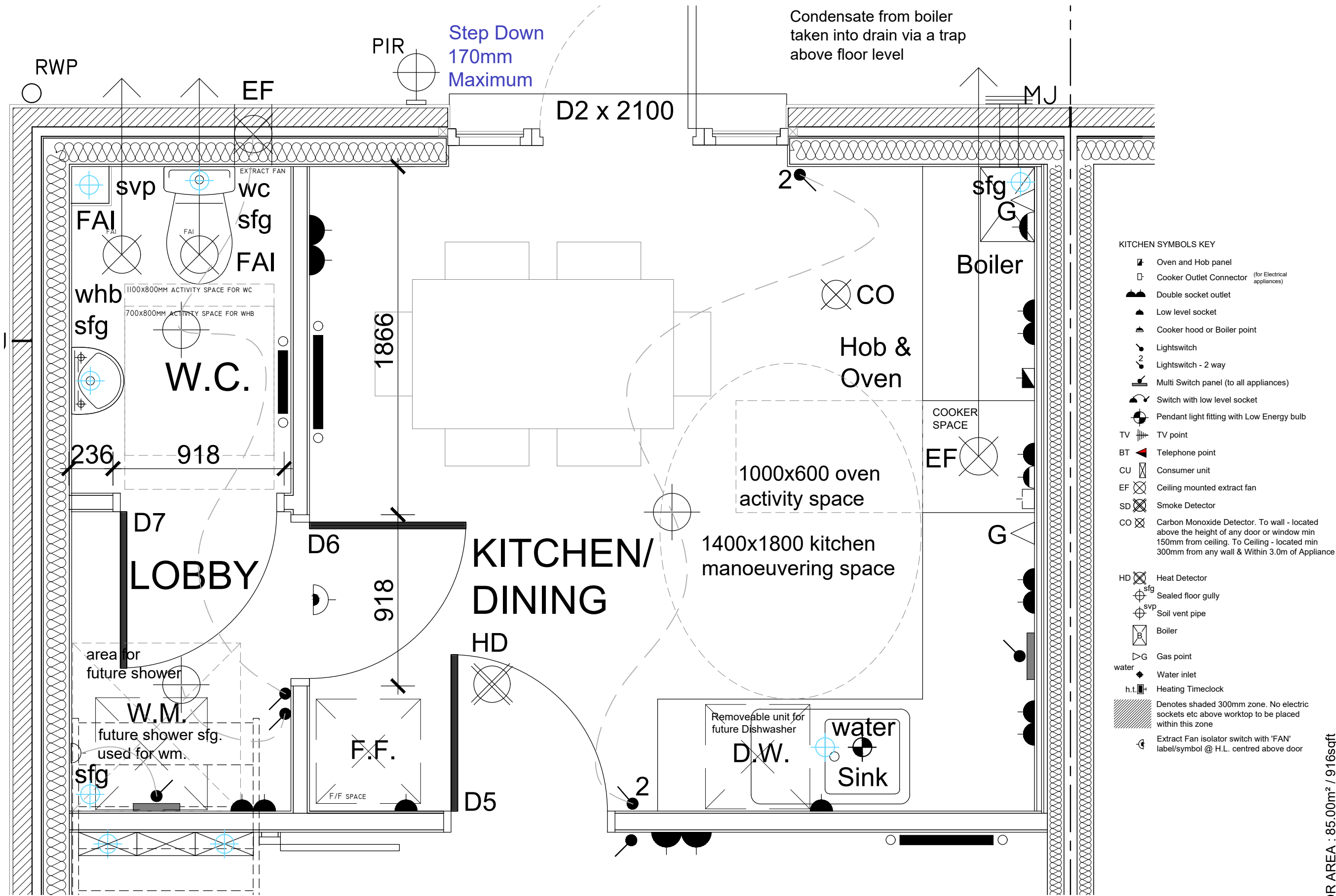

- KITCHEN SYMBOLS KEY**
- ☐ Oven and Hob panel
 - ☐ Cooker Outlet Connector (for Electrical appliances)
 - ☐ Double socket outlet
 - Low level socket
 - ☐ Cooker hood or Boiler point
 - ☐ Lightswitch
 - ☐ Lightswitch - 2 way
 - ☐ Multi Switch panel (to all appliances)
 - ☐ Switch with low level socket
 - ☐ Pendant light fitting with Low Energy bulb
 - TV TV point
 - BT Telephone point
 - CU Consumer unit
 - EF Ceiling mounted extract fan
 - SD Smoke Detector
 - CO Carbon Monoxide Detector. To wall - located above the height of any door or window min 150mm from ceiling. To Ceiling - located min 300mm from any wall & Within 3.0m of Appliance
 - HD Heat Detector
 - ⊕ sfg Sealed floor gully
 - ⊕ svp Soil vent pipe
 - ☐ Boiler
 - ⊕ G Gas point
 - water Water inlet
 - h.t. Heating Timeclock
 - ▨ Denotes shaded 300mm zone. No electric sockets etc above worktop to be placed within this zone
 - ☐ Extract Fan isolator switch with 'FAN' label/symbol @ H.L. centred above door

TOTAL FLOOR AREA : 85.00m² / 916sqft

Sales Name: **ROSSDHU**

House Type Code: **BRHU 02GS**

Spec: **RSL** Drawing No: 2020/STAS/08

Drawn: **GDT** Checked: **AB** Scale: 1:20@A3 Date: Jan 19

KITCHEN

Description: Refer to Data Sheet

Date: April 23

Thermal Spec:

BLUE (det)



BARRATT
DEVELOPMENTS PLC

WARNING TO HOUSE-BUYERS/PURCHASERS.
Buyers are warned that this is a working drawing and the contents of this drawing are subject to change during the construction process. The layout, dimensions, materials and fixtures shown may alter in respect of individual properties. Whilst we make every effort to ensure our drawings are up to date there may be changes in regulations and/or re-planning. Purchasers are advised to check with the Sales Adviser whether any alterations have been made to this drawing. The contents of this drawing do not constitute a contract, part of any contract or warranty unless otherwise stated. The drawing is intended to be used for the purposes of entering into a contract to purchase any property.



FRONT ELEVATION

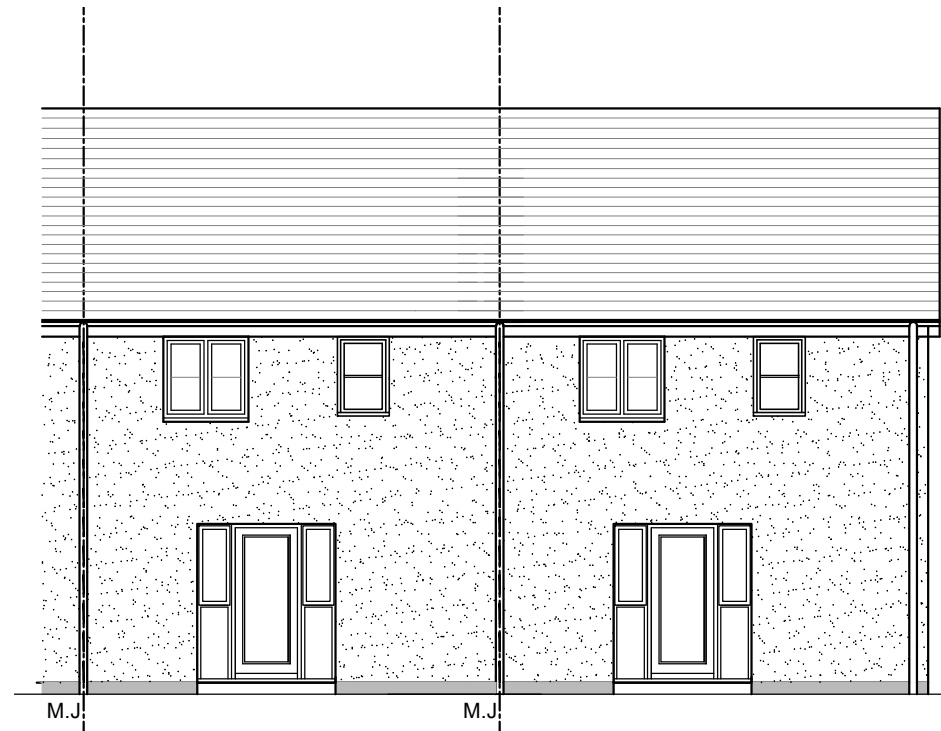

REAR ELEVATION

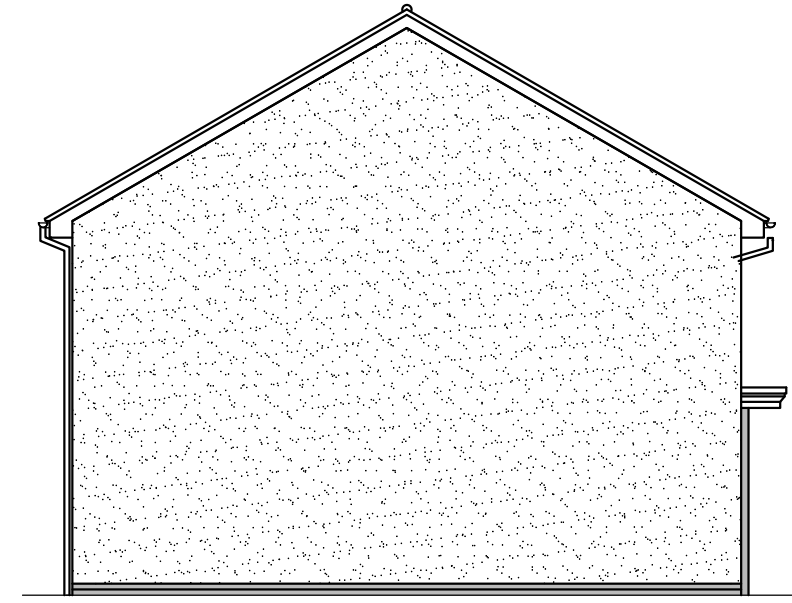

SIDE ELEVATION

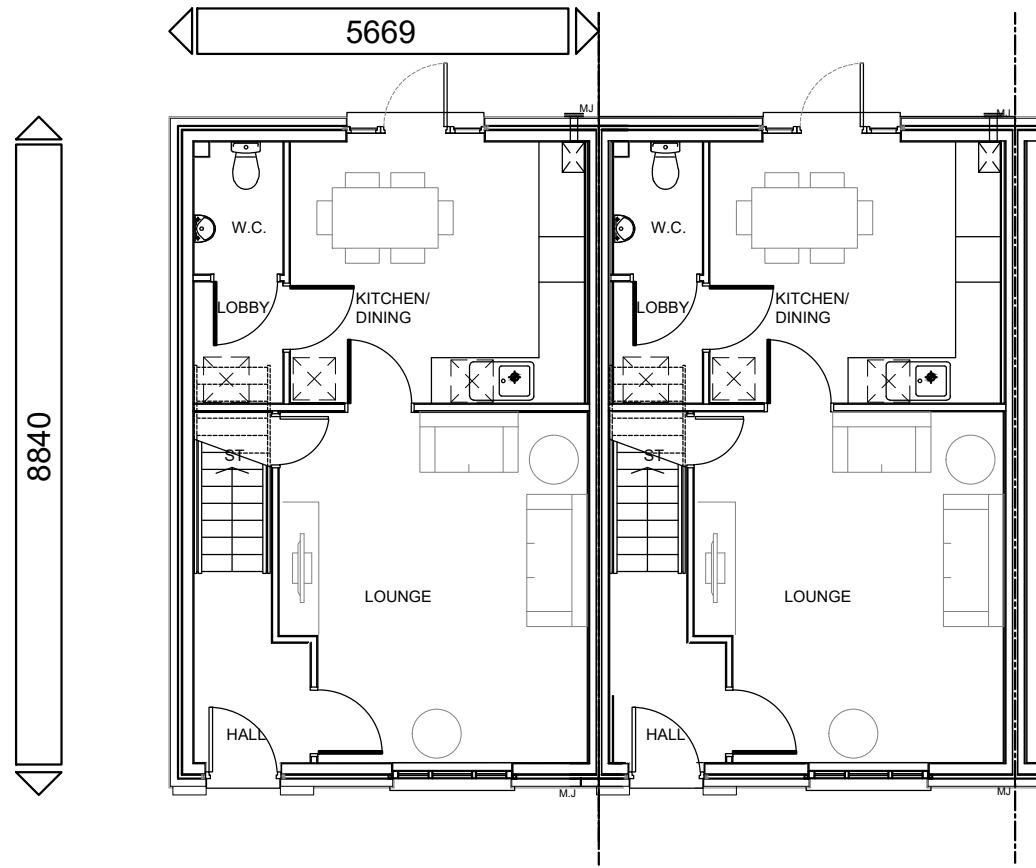

GROUND FLOOR PLAN

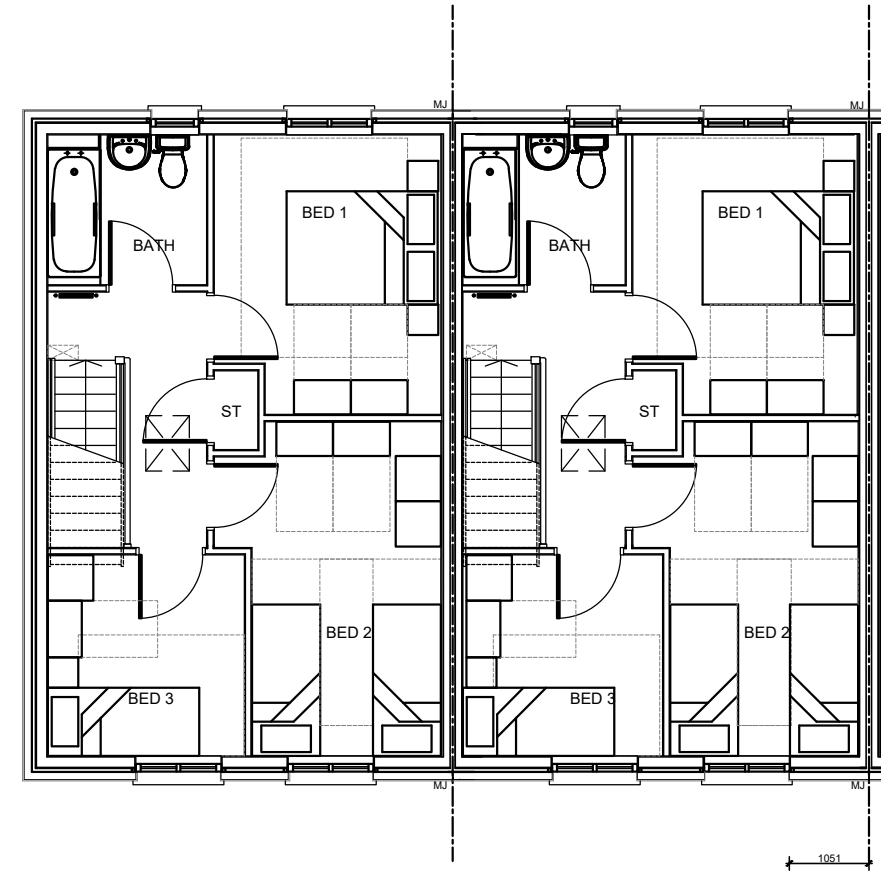

FIRST FLOOR PLAN

TOTAL FLOOR AREA : 85.00m² / 916sqft

Sales Name: **ROSSDHU**

House Type Code: **BRHU 02GS**

Spec: **RSL** Drawing No: 2020/STAS/01

Drawn: **GDT** Checked: **AB** Scale: 1:100@A3 Date: Jan 19

PLANNING

Rev: **A** Description: Refer to Data Sheet

Date: April 23

Thermal Spec:

BLUE (det)



BARRATT
DEVELOPMENTS PLC

WARNING TO HOUSE-PURCHASERS.
Buyers are warned that this is a working drawing and the contents of this drawing may be subject to change during the progress of the project. The layout, dimensions and details shown are for information only and are not intended to be used for construction. The finishes or features shown may alter in respect of individual properties. Whilst we make every effort to ensure our drawings are up to date there may be changes in the design or specifications of the property from time to time due to an unavoidable delay in updating these due to changes in regulations and/or re-planning. Purchasers are advised to check with the Sales Adviser whether any alterations have been made to this drawing. The contents of this drawing do not constitute a contract, part of any contract or warranty unless otherwise stated. Purchasers are advised to rely upon the drawings for the purposes of entering into a contract to purchase any property.

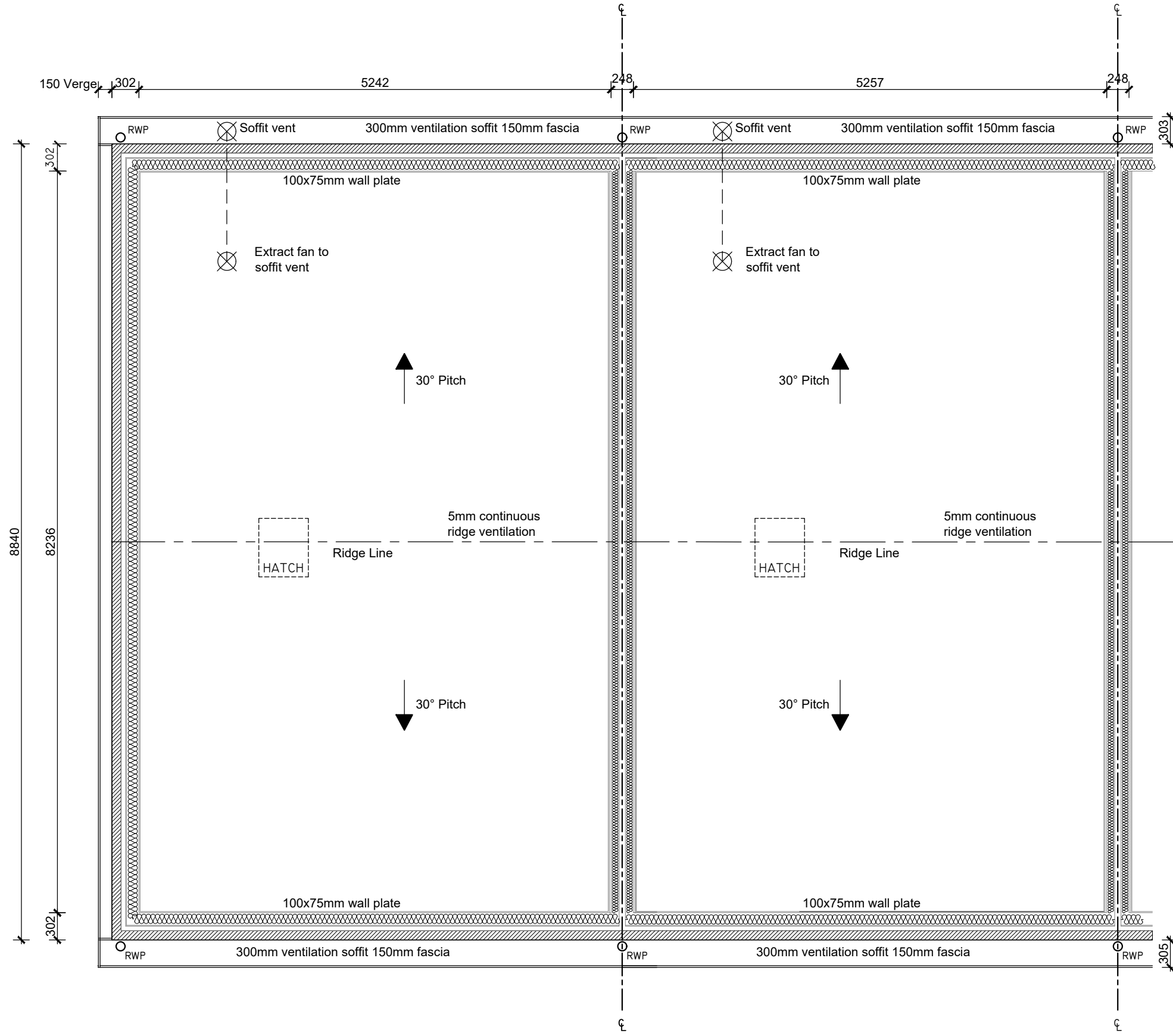

300mm Ventilated soffit
150mm fascia

Trussed rafters at 600mm centres.
Ceiling ties, longitudinals, diagonals to
be in strict accordance with B.S.5268
part.3 : 2006. Roof plan to specialist
design with calculations and full bracing
details submitted prior to work.

Layout shown is indicative only and
represents basic roof design. Truss
types and spacings to specialist design.
See specialist details and drawings for
exact layout.

5mm continuous ridge ventilation

WALL KEY:

Blockwork as Engineer's
Specification

Thermal Spec:
BLUE (det)

BARRATT
DEVELOPMENTS PLC

ROOF PLAN	
Rev: A	Description: Refer to Data Sheet
Date:	April 23

WARNING TO HOUSE-PURCHASERS.
Buyers are warned that this is a working drawing and the contents of this drawing
may be subject to change during the progress of the project. The layout,
dimensions and details shown are for information only and are not intended to be
used for construction. The finishes or features shown may alter in respect of individual properties.
Whilst we make every effort to ensure our drawings are up to date there may
be changes in regulations and/or re-planning. Purchasers are advised to check with the Sales
Adviser whether any alterations have been made to this drawing. The contents of
this drawing do not constitute a contract, part of any contract or warranty unless
expressly stated otherwise. The drawing is to be used for the purposes of entering into a contract to purchase any property.

TOTAL FLOOR AREA : 85.00m² / 916sqft

Sales Name: **ROSSDHU**
House Type Code: **BRHU 02GS**
Spec: **RSL** Drawing No: **2020/STAS/06**
Drawn: **GDT** Checked: **AB** Scale: **1:50@A3** Date:

Provide Cavity Tray over Lintel

Min code 4 lead flashing and cavity trays to raking abutments

Propriety weep holes at 450mm c/cs

STAIRCASE NOTES:
 13 No. risers at 197.46mm
 12 No. goings at 225mm
 Stair pitch 41.27°

Level threshold to Standard Detail

Level approach to front entrance max gradient 1:20 min1200mm width

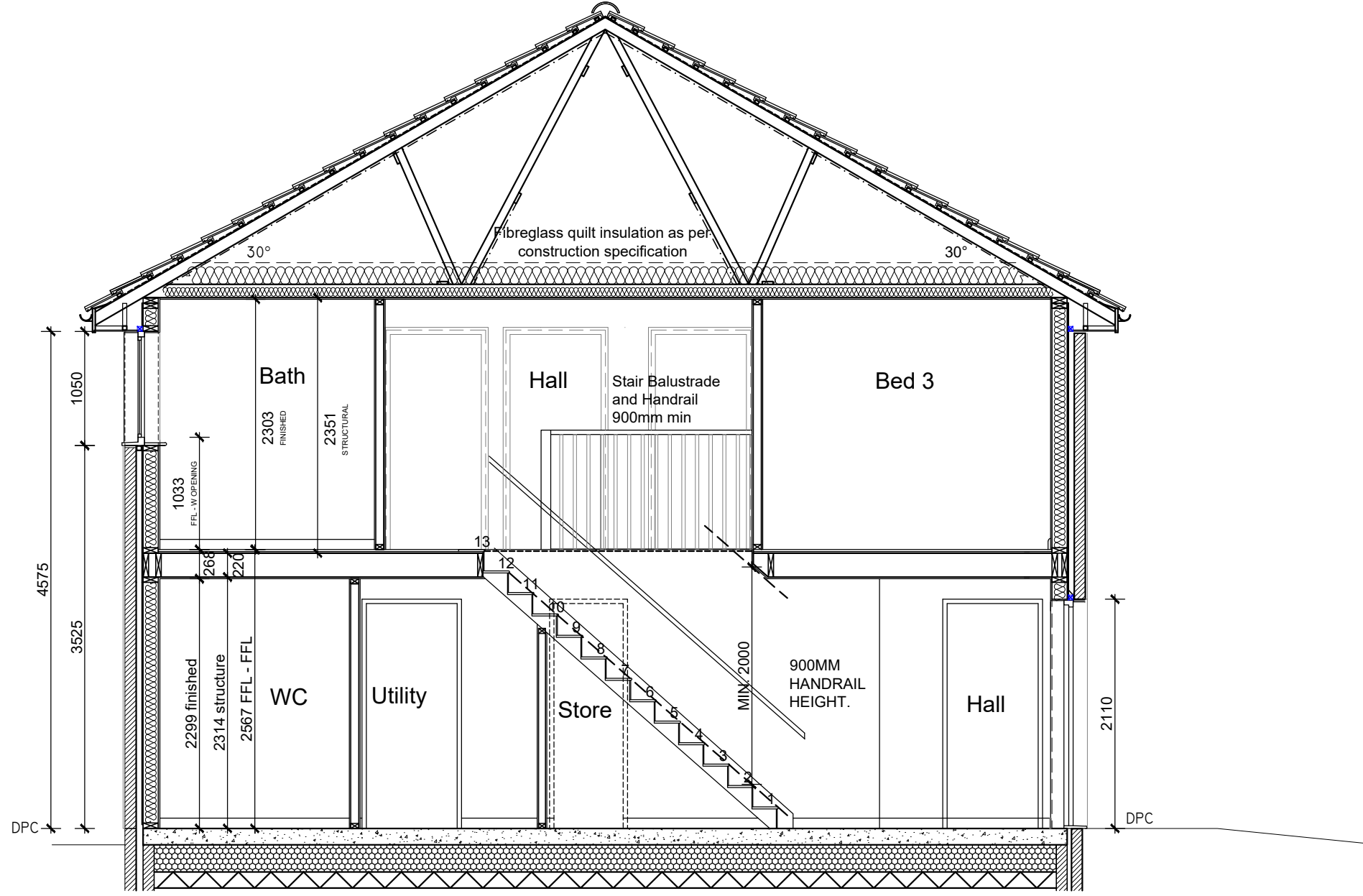

SECTION A-A

TOTAL FLOOR AREA : 85.00m² / 916sqft

Sales Name: **ROSSDHU**

House Type Code: **BRHU 02GS**

Spec: **RSL** Drawing No: 2020/STAS/07

Drawn: **GDT** Checked: **AB** Scale: 1:50@A3 Date: Jan 19

SECTION A-A

Rev: A
 Description: Refer to Data Sheet

Date: April 23

Thermal Spec:

BLUE (det)



BARRATT
 DEVELOPMENTS PLC

WARNING TO HOUSE-PURCHASERS.
 Buyers are warned that this is a working drawing and the contents of this drawing may be amended during the progress of the project. The layout, dimensions and details shown are for information only and are not intended to be used for construction. The finishes or features shown may alter in response to individual properties. Whilst we make every effort to ensure our drawings are up to date there may be changes in regulations and/or re-planning. Purchasers are advised to check with the Sales Adviser whether any alterations have been made to this drawing. The contents of this drawing do not constitute a contract, part of any contract or warranty unless otherwise stated. The drawing is intended for use only for the purposes of entering into a contract to purchase any property.

MEASUREMENTS ARE APPROXIMATE

①

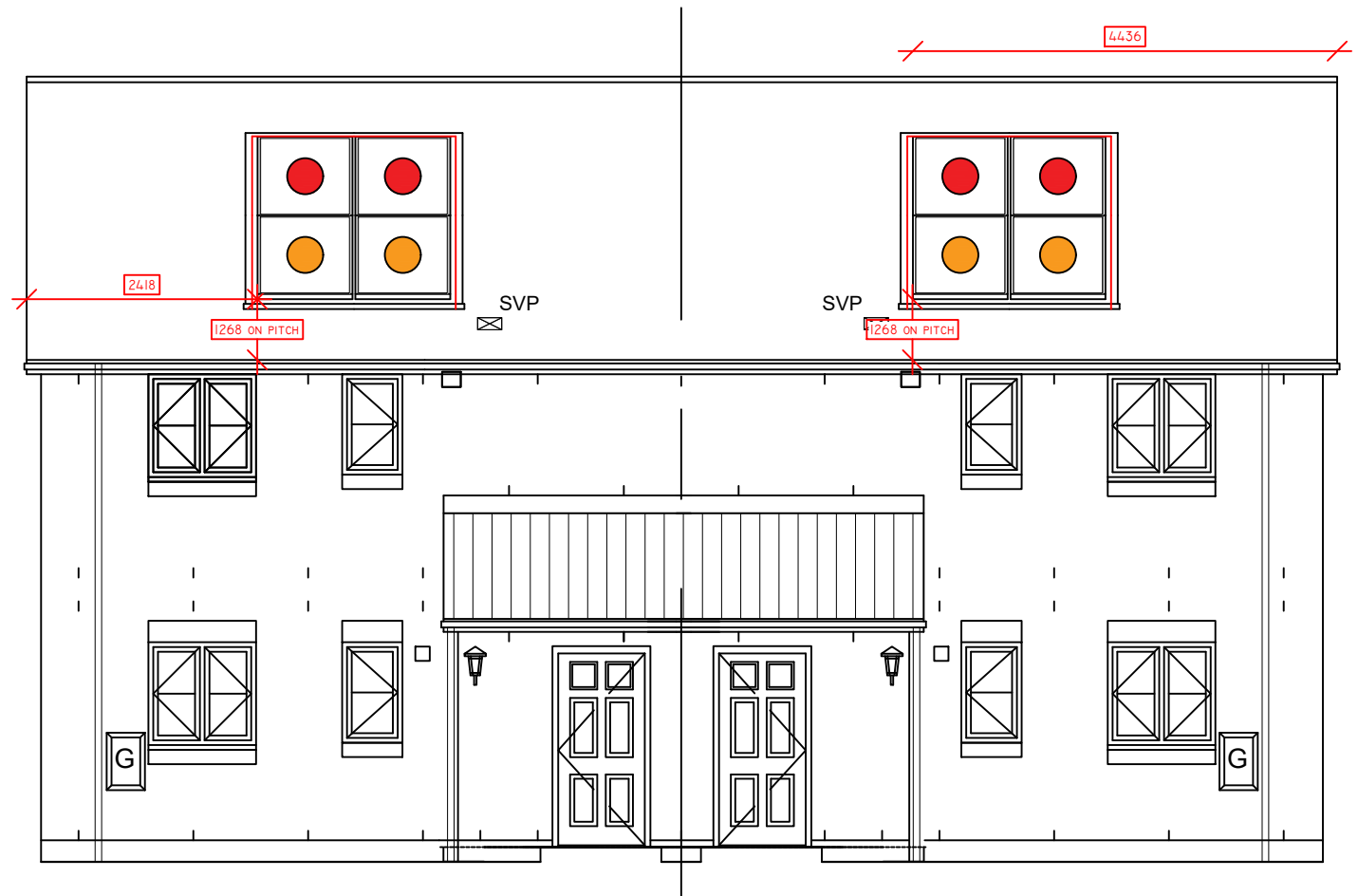

AS SHOWN -

MIRRORED -

FRONT ELEVATION

SOLAR PV ARRANGEMENT
BARRATT HOMES
STAS AFFORDABLE 2020
ARDLUI GF & ARDVORLICH IF
TBCPV

STRING KEY

●	STRING 1	2	●	STRING 2	2
●	STRING 3	0	●	STRING 4	0
●	STRING 5	0	●	STRING 6	0
●	STRING 7	0	●	STRING 8	0

SYSTEM TYPE: IN ROOF
 SYSTEM NAME: VIRIDIAN
 POSITION: PORTRAIT
 SPLIT ELEVATION: NO
 PITCH: 30°
 MODULE QUANTITY: 2 & 2

HOUSE TYPE: ARDLUI & ARDVORLICH
 DRAWN BY: *3Z
 DATE: *4Z
 CHECKED BY: *5Z
 DATE: *6Z
 SCALE @ A3: 1:75
 REVISION: *7Z

DISCLAIMER:
 DESIGNS CREATED BY Eco2SOLAR ARE BASED ON INFORMATION PROVIDED TO US FROM THE CLIENT. Eco2SOLAR CANNOT ACCEPT LIABILITY FOR ERRORS RESULTING FROM INCORRECT INFORMATION SUPPLIED FROM THE CLIENT

②

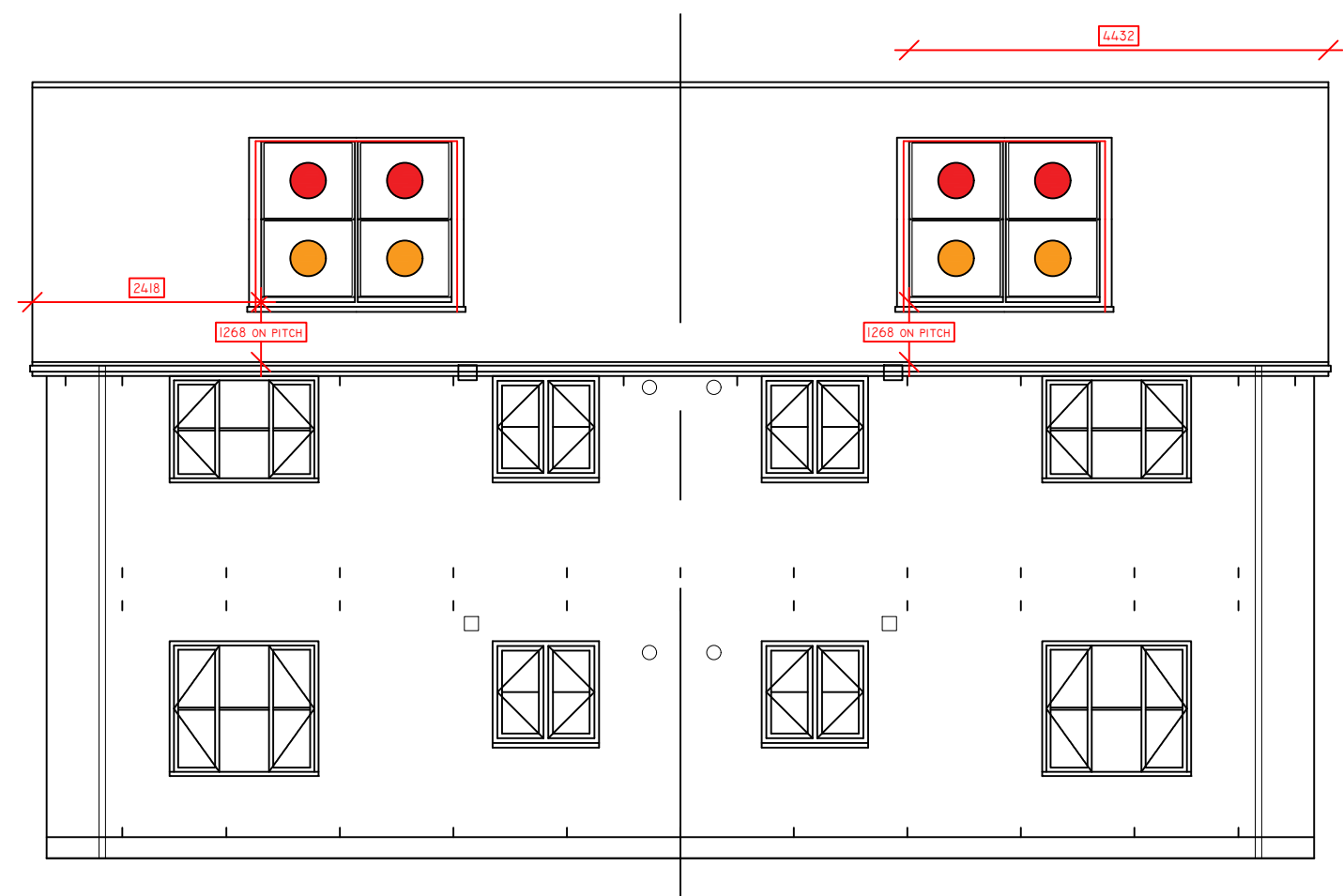

AS SHOWN -

MIRRORED -

REAR ELEVATION

SUMMERFIELD HOUSE, ARTHUR DRIVE
 HOO FARM INDUSTRIAL ESTATE
 KIDDERMINSTER
 WORCESTERSHIRE
 DY11 7SL

MEASUREMENTS ARE APPROXIMATE

①

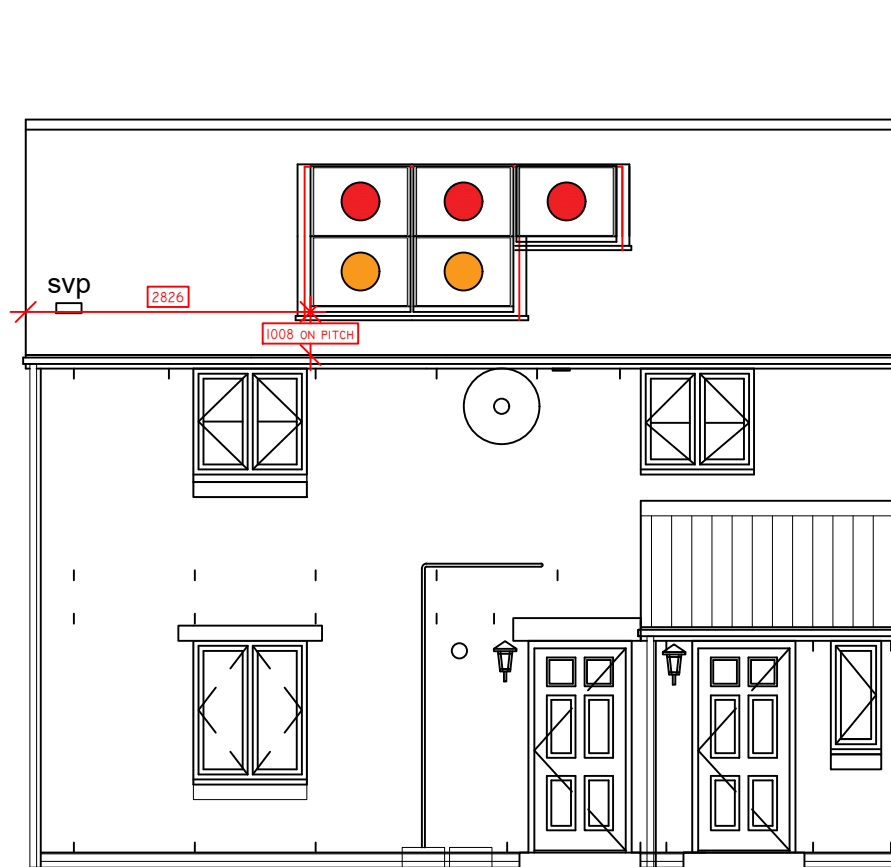

AS SHOWN -

MIRRORED -

FRONT ELEVATION

SOLAR PV ARRANGEMENT
BARRATT HOMES
STAS AFFORDABLE 2020
CAILNESS GF & CAMERON IF
TBCPV

STRING KEY

●	STRING 1	3	●	STRING 2	2
●	STRING 3	0	●	STRING 4	0
●	STRING 5	0	●	STRING 6	0
●	STRING 7	0	●	STRING 8	0

SYSTEM TYPE: IN ROOF
 SYSTEM NAME: VIRIDIAN
 POSITION: PORTRAIT
 SPLIT ELEVATION: NO
 PITCH: 25°
 MODULE QUANTITY: 3 & 2

HOUSE TYPE: CAILNESS & CAMERON
 DRAWN BY: *3Z
 DATE: *4Z
 CHECKED BY: *5Z
 DATE: *6Z
 SCALE @ A3: 1:75
 REVISION: *7Z

DISCLAIMER:
 DESIGNS CREATED BY Eco2SOLAR ARE BASED ON INFORMATION PROVIDED TO US FROM THE CLIENT. Eco2SOLAR CANNOT ACCEPT LIABILITY FOR ERRORS RESULTING FROM INCORRECT INFORMATION SUPPLIED FROM THE CLIENT

eco₂solar
 SUMMERFIELD HOUSE, ARTHUR DRIVE
 HOO FARM INDUSTRIAL ESTATE
 KIDDERMINSTER
 WORCESTERSHIRE
 DY11 7SL

②

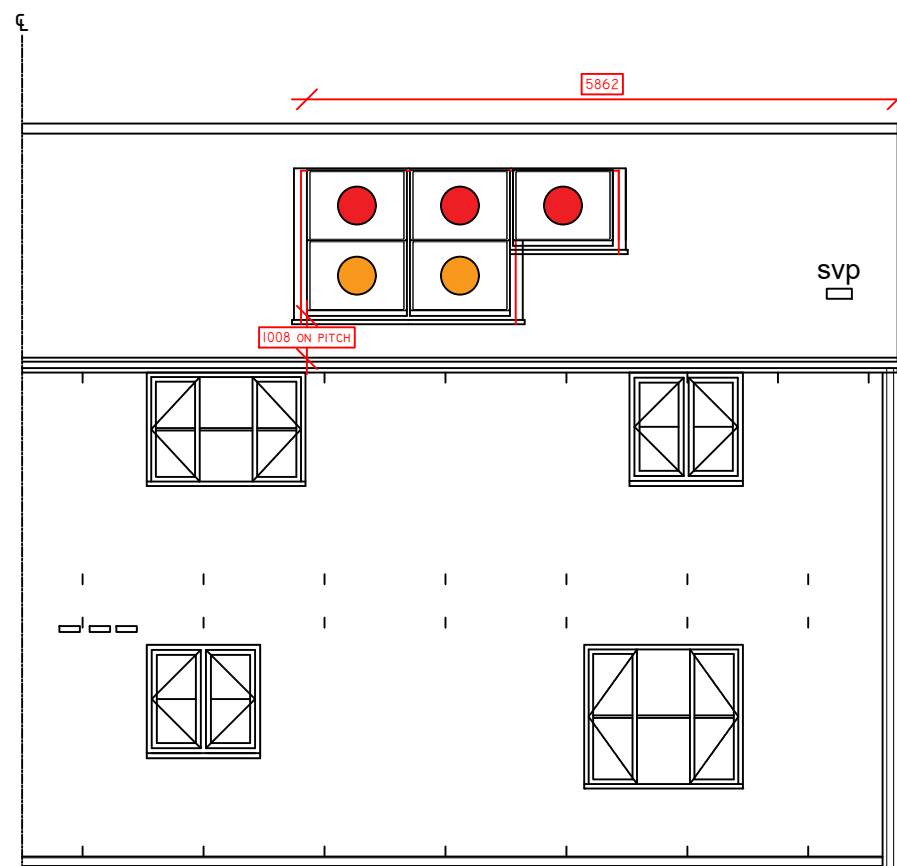

AS SHOWN -

MIRRORED -

REAR ELEVATION

MEASUREMENTS ARE APPROXIMATE

①

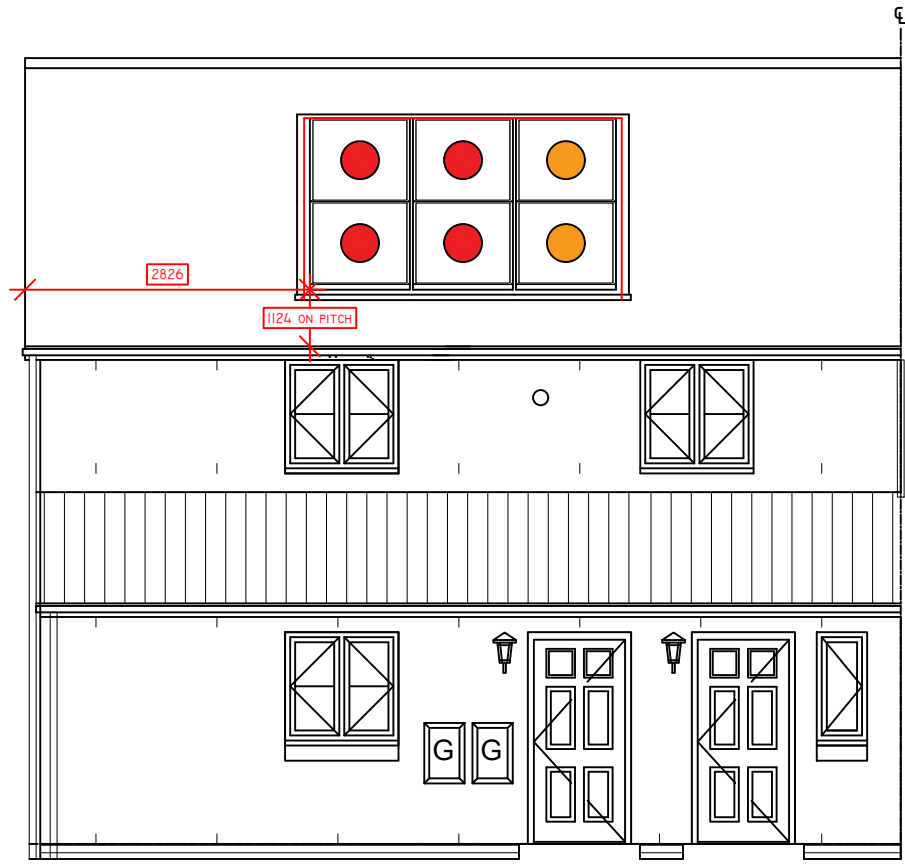

AS SHOWN -

MIRRORED -

FRONT ELEVATION

SOLAR PV ARRANGEMENT
BARRATT HOMES
STAS AFFORDABLE 2020
CASHELL GF & ENDRICK IF
TBCPV

STRING KEY

●	STRING 1	4	●	STRING 2	2
●	STRING 3	0	●	STRING 4	0
●	STRING 5	0	●	STRING 6	0
●	STRING 7	0	●	STRING 8	0

SYSTEM TYPE: IN ROOF
 SYSTEM NAME: VIRIDIAN
 POSITION: PORTRAIT
 SPLIT ELEVATION: NO
 PITCH: 30°
 MODULE QUANTITY: 4 & 2

HOUSE TYPE: CASHELL & ENDRICK
 DRAWN BY: *3Z
 DATE: *4Z
 CHECKED BY: *5Z
 DATE: *6Z
 SCALE @ A3: 1:75
 REVISION: *7Z

DISCLAIMER:
 DESIGNS CREATED BY Eco2SOLAR ARE BASED ON INFORMATION PROVIDED TO US FROM THE CLIENT. Eco2SOLAR CANNOT ACCEPT LIABILITY FOR ERRORS RESULTING FROM INCORRECT INFORMATION SUPPLIED FROM THE CLIENT

eco₂solar
 SUMMERFIELD HOUSE, ARTHUR DRIVE
 HOO FARM INDUSTRIAL ESTATE
 KIDDERMINSTER
 WORCESTERSHIRE
 DY11 7SL

②

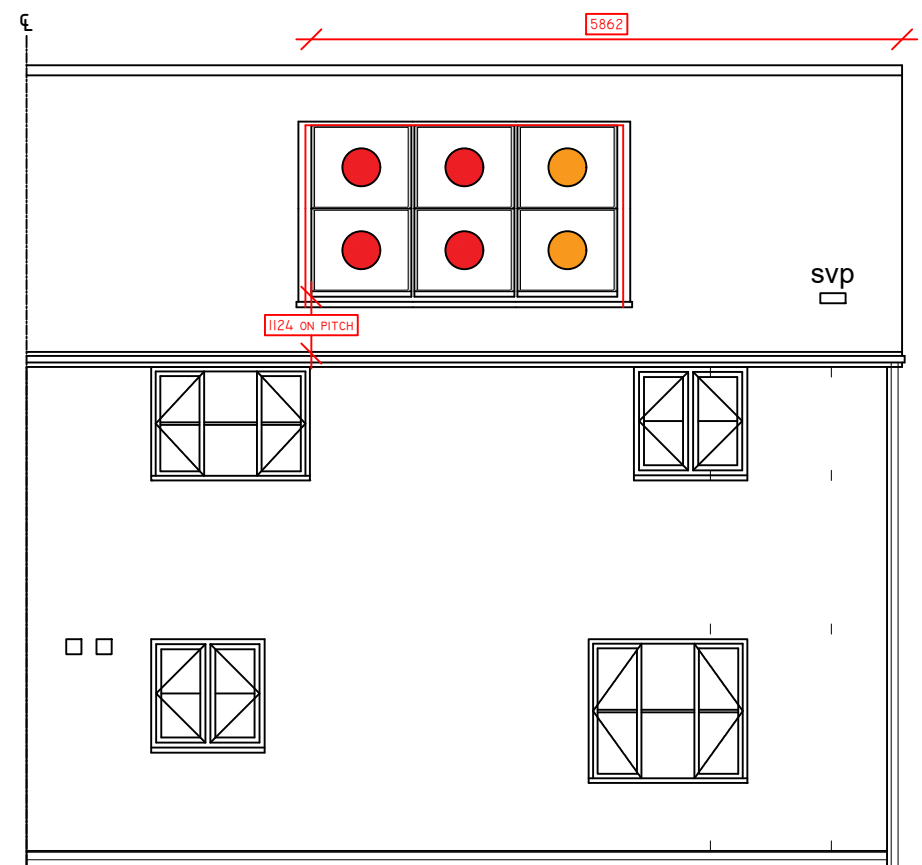

AS SHOWN -

MIRRORED -

REAR ELEVATION

MEASUREMENTS ARE APPROXIMATE

1

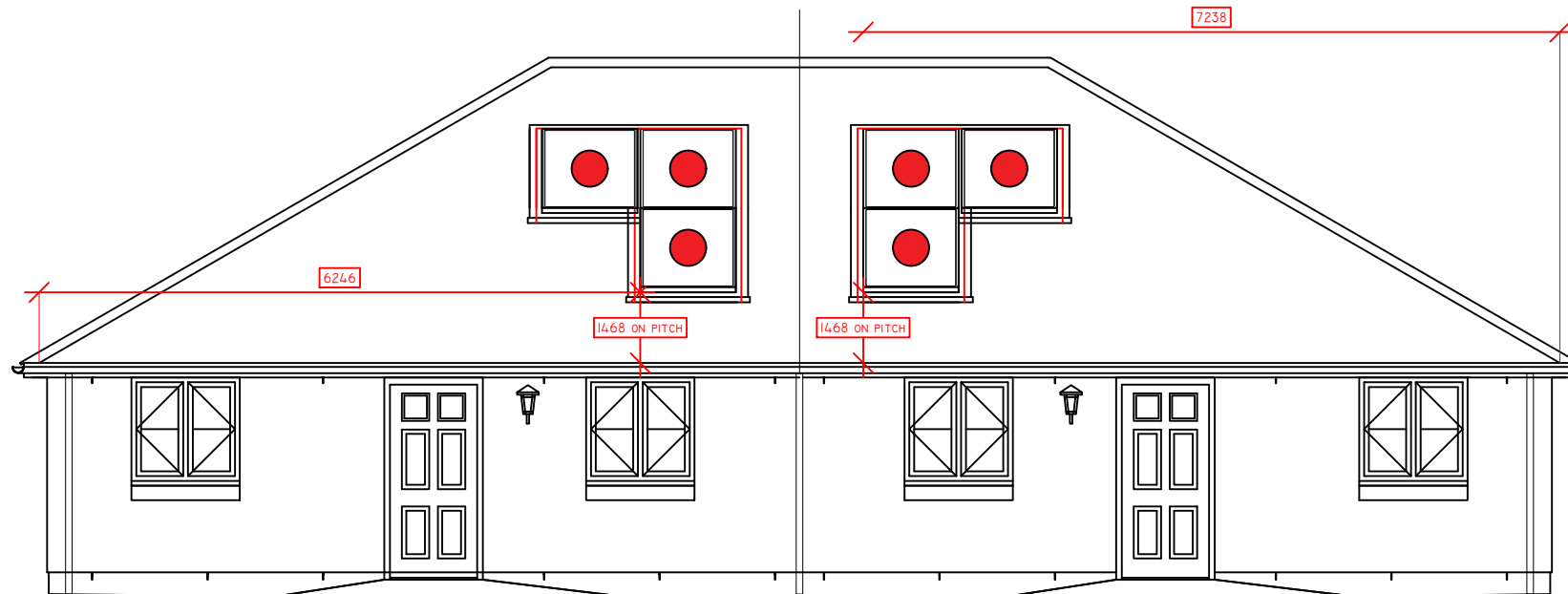

AS SHOWN -

MIRRORED -

FRONT ELEVATION

SOLAR PV ARRANGEMENT
BARRATT HOMES
STAS AFFORDABLE 2020
FINLAS
TBCPV

STRING KEY

●	STRING 1	3	●	STRING 2	0
●	STRING 3	0	●	STRING 4	0
●	STRING 5	0	●	STRING 6	0
●	STRING 7	0	●	STRING 8	0

SYSTEM TYPE: IN ROOF
 SYSTEM NAME: VIRIDIAN
 POSITION: PORTRAIT
 SPLIT ELEVATION: NO
 PITCH: 30°
 MODULE QUANTITY: 3

HOUSE TYPE: FINLAS
 DRAWN BY: *3Z
 DATE: *4Z
 CHECKED BY: *5Z
 DATE: *6Z
 SCALE @ A3: 1:75
 REVISION: *7Z

DISCLAIMER:
 DESIGNS CREATED BY ECO2SOLAR ARE BASED ON INFORMATION PROVIDED TO US FROM THE CLIENT. ECO2SOLAR CANNOT ACCEPT LIABILITY FOR ERRORS RESULTING FROM INCORRECT INFORMATION SUPPLIED FROM THE CLIENT

2

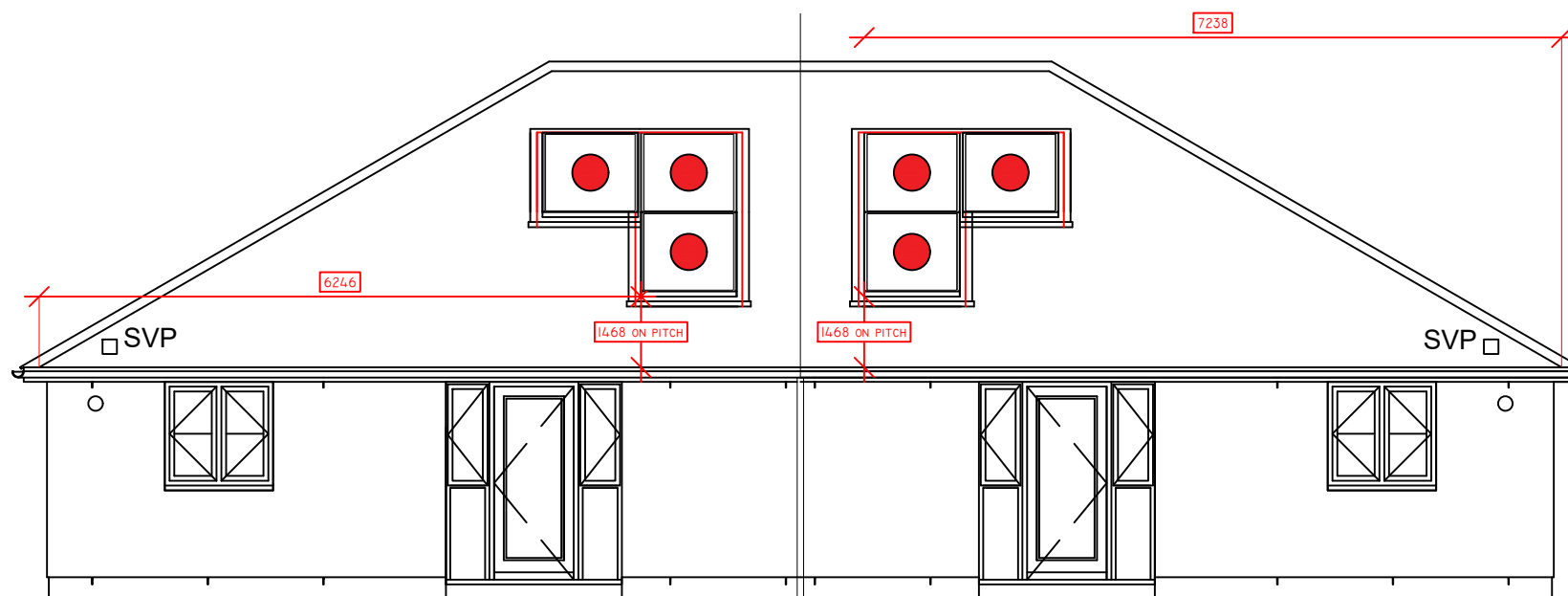

AS SHOWN -

MIRRORED -

REAR ELEVATION

eco₂solar
 SUMMERFIELD HOUSE, ARTHUR DRIVE
 HOO FARM INDUSTRIAL ESTATE
 KIDDERMINSTER
 WORCESTERSHIRE
 DY11 7SL

MEASUREMENTS ARE APPROXIMATE

①

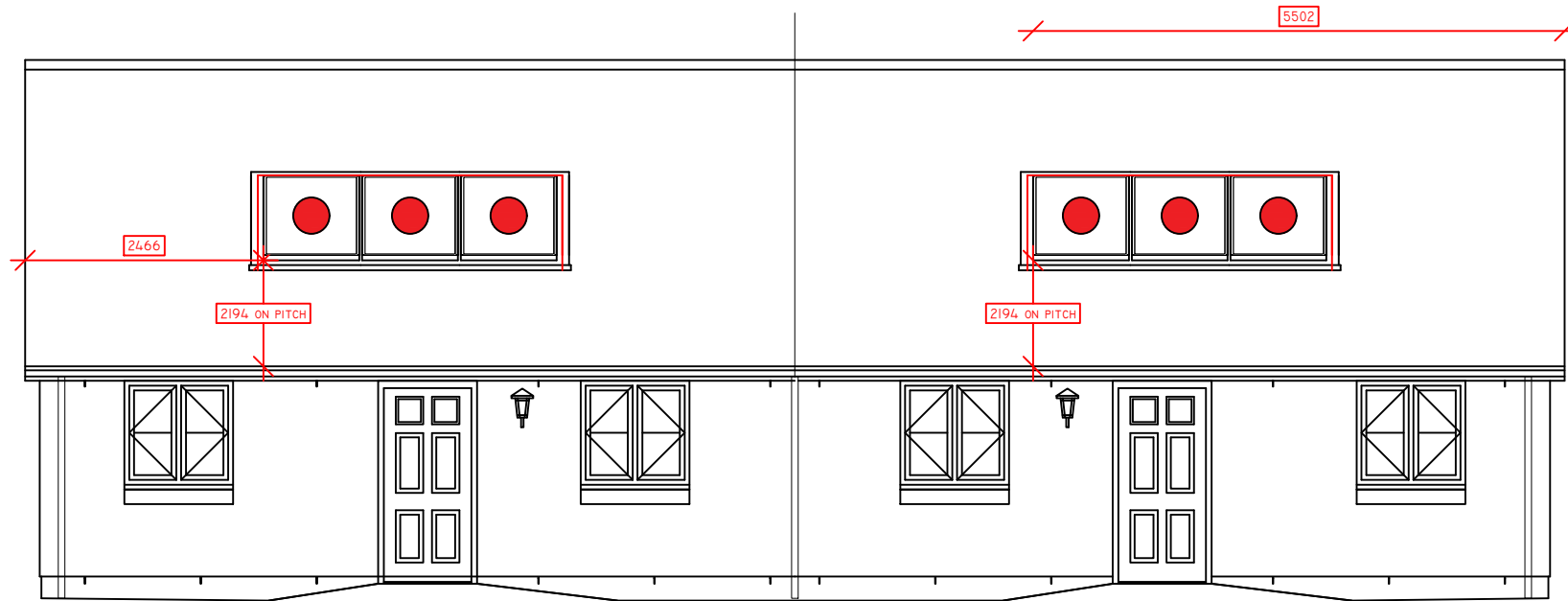

AS SHOWN -

MIRRORED -

FRONT ELEVATION

**SOLAR PV ARRANGEMENT
BARRATT HOMES
STAS AFFORDABLE 2020
FINLAS GABLE
TBCPV**

STRING KEY

●	STRING 1	3	●	STRING 2	0
●	STRING 3	0	●	STRING 4	0
●	STRING 5	0	●	STRING 6	0
●	STRING 7	0	●	STRING 8	0

SYSTEM TYPE: IN ROOF
 SYSTEM NAME: VIRIDIAN
 POSITION: PORTRAIT
 SPLIT ELEVATION: NO
 PITCH: 30°
 MODULE QUANTITY: 3

HOUSE TYPE: FINLAS GABLE
 DRAWN BY: *3Z
 DATE: *4Z
 CHECKED BY: *5Z
 DATE: *6Z
 SCALE @ A3: 1:75
 REVISION: *7Z

DISCLAIMER:
 DESIGNS CREATED BY Eco2SOLAR ARE BASED ON INFORMATION PROVIDED TO US FROM THE CLIENT. Eco2SOLAR CANNOT ACCEPT LIABILITY FOR ERRORS RESULTING FROM INCORRECT INFORMATION SUPPLIED FROM THE CLIENT

②

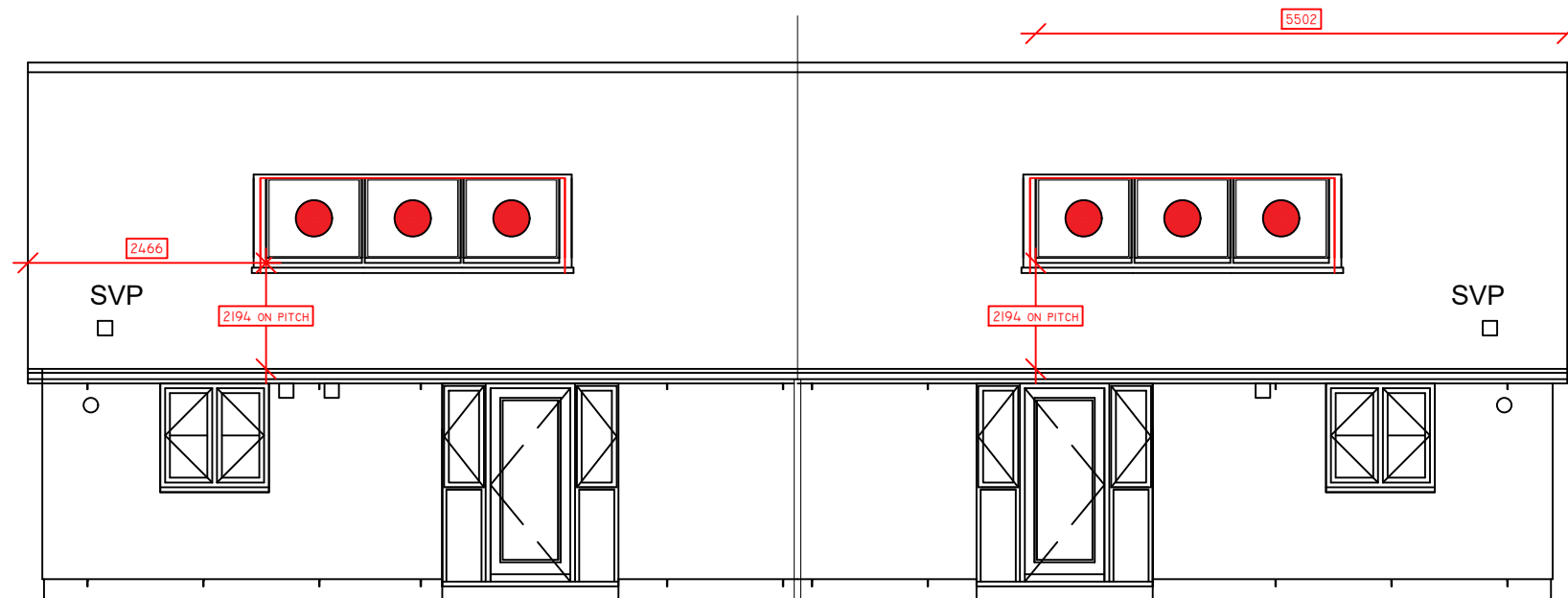

AS SHOWN -

MIRRORED -

REAR ELEVATION

SUMMERFIELD HOUSE, ARTHUR DRIVE
 HOO FARM INDUSTRIAL ESTATE
 KIDDERMINSTER
 WORCESTERSHIRE
 DY11 7SL

MEASUREMENTS ARE APPROXIMATE

①

AS SHOWN -

MIRRORED -

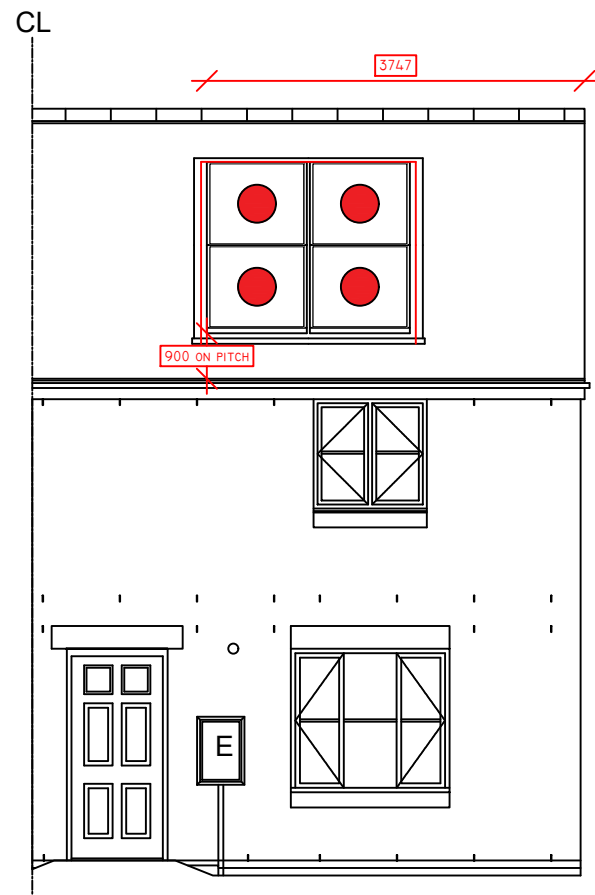

FRONT ELEVATION

**SOLAR PV ARRANGEMENT
BARRATT HOMES
STAS AFFORDABLE 2020
INVERBEG
TBCPV**

STRING KEY

●	STRING 1	4	●	STRING 2	0
●	STRING 3	0	●	STRING 4	0
●	STRING 5	0	●	STRING 6	0
●	STRING 7	0	●	STRING 8	0

SYSTEM TYPE: IN ROOF
 SYSTEM NAME: VIRIDIAN
 POSITION: PORTRAIT
 SPLIT ELEVATION: NO
 PITCH: 30°
 MODULE QUANTITY: 4

HOUSE TYPE: INVERBEG
 DRAWN BY: *3Z
 DATE: *4Z
 CHECKED BY: *5Z
 DATE: *6Z
 SCALE @ A3: 1:75
 REVISION: *7Z

DISCLAIMER:
 DESIGNS CREATED BY Eco2SOLAR ARE BASED ON
 INFORMATION PROVIDED TO US FROM THE CLIENT. Eco2SOLAR
 CANNOT ACCEPT LIABILITY FOR ERRORS RESULTING FROM
 INCORRECT INFORMATION SUPPLIED FROM THE CLIENT

eco₂solar
 SUMMERFIELD HOUSE, ARTHUR DRIVE
 HOO FARM INDUSTRIAL ESTATE
 KIDDERMINSTER
 WORCESTERSHIRE
 DY11 7SL

AS SHOWN -

MIRRORED -

②

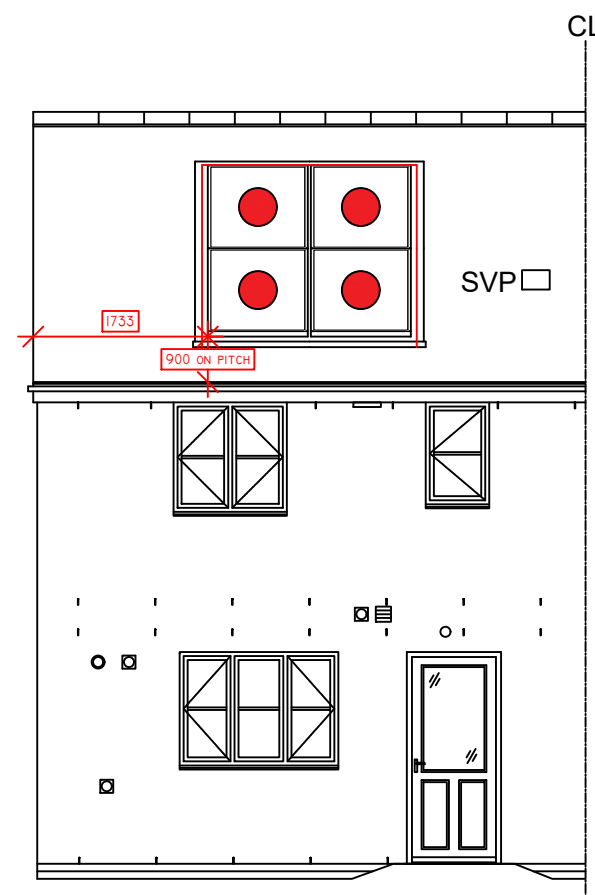

REAR ELEVATION

MEASUREMENTS ARE APPROXIMATE

1

DUAL ELEVATION

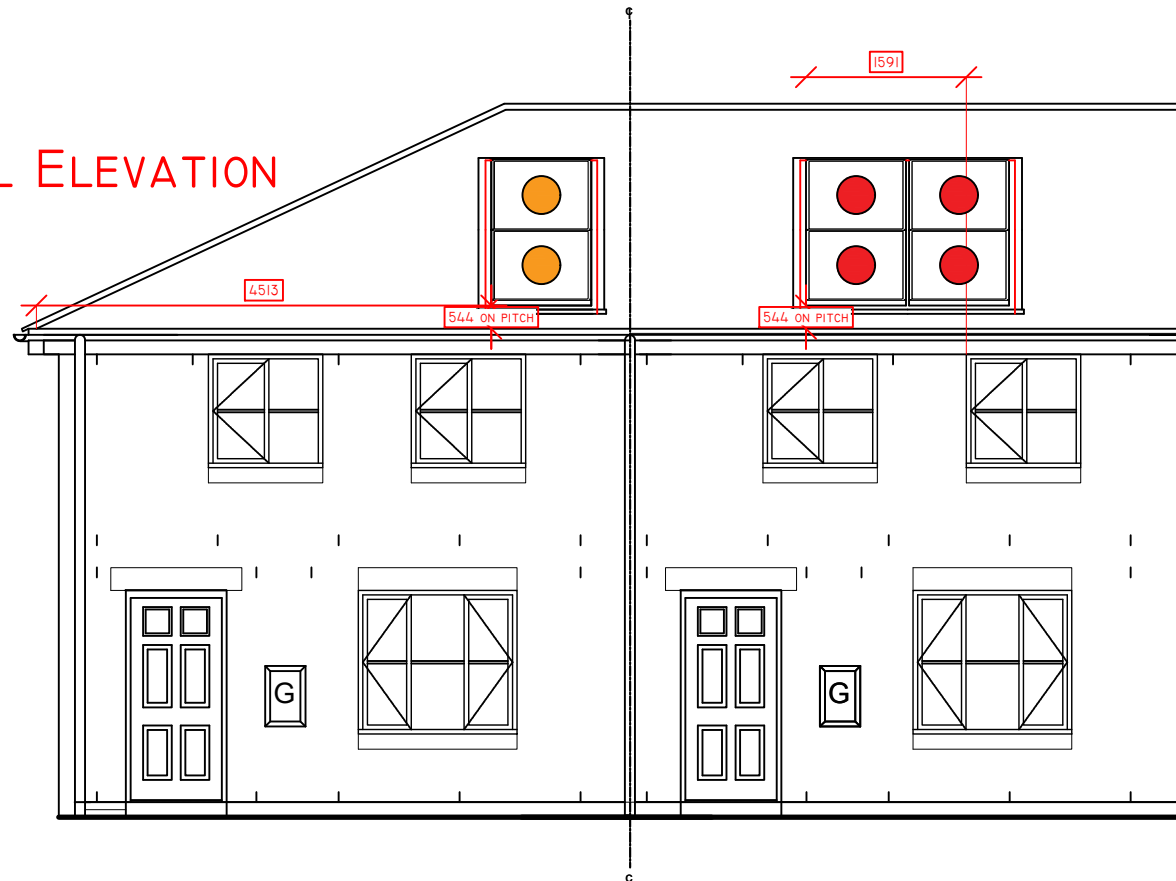

AS SHOWN -

MIRRORED -

FRONT ELEVATION

**SOLAR PV ARRANGEMENT
BARRATT HOMES
STAS AFFORDABLE 2020
ROSSDHU ET-MT
TBCPV**

STRING KEY

● STRING 1	4	● STRING 2	2
● STRING 3	2	● STRING 4	0
● STRING 5	0	● STRING 6	0
● STRING 7	0	● STRING 8	0

SYSTEM TYPE:	IN ROOF
SYSTEM NAME:	VIRIDIAN
POSITION:	PORTRAIT
SPLIT ELEVATION:	YES
PITCH:	25°
MODULE QUANTITY:	4

HOUSE TYPE:	ROSSDHU
DRAWN BY:	*3Z
DATE:	*4Z
CHECKED BY:	*5Z
DATE:	*6Z
SCALE @ A3:	1:75
REVISION:	*7Z

DISCLAIMER:
DESIGNS CREATED BY ECO2SOLAR ARE BASED ON INFORMATION PROVIDED TO US FROM THE CLIENT. ECO2SOLAR CANNOT ACCEPT LIABILITY FOR ERRORS RESULTING FROM INCORRECT INFORMATION SUPPLIED FROM THE CLIENT

eco₂solar
SUMMERFIELD HOUSE, ARTHUR DRIVE
HOO FARM INDUSTRIAL ESTATE
KIDDERMINSTER
WORCESTERSHIRE
DY11 7SL

2

DUAL ELEVATION

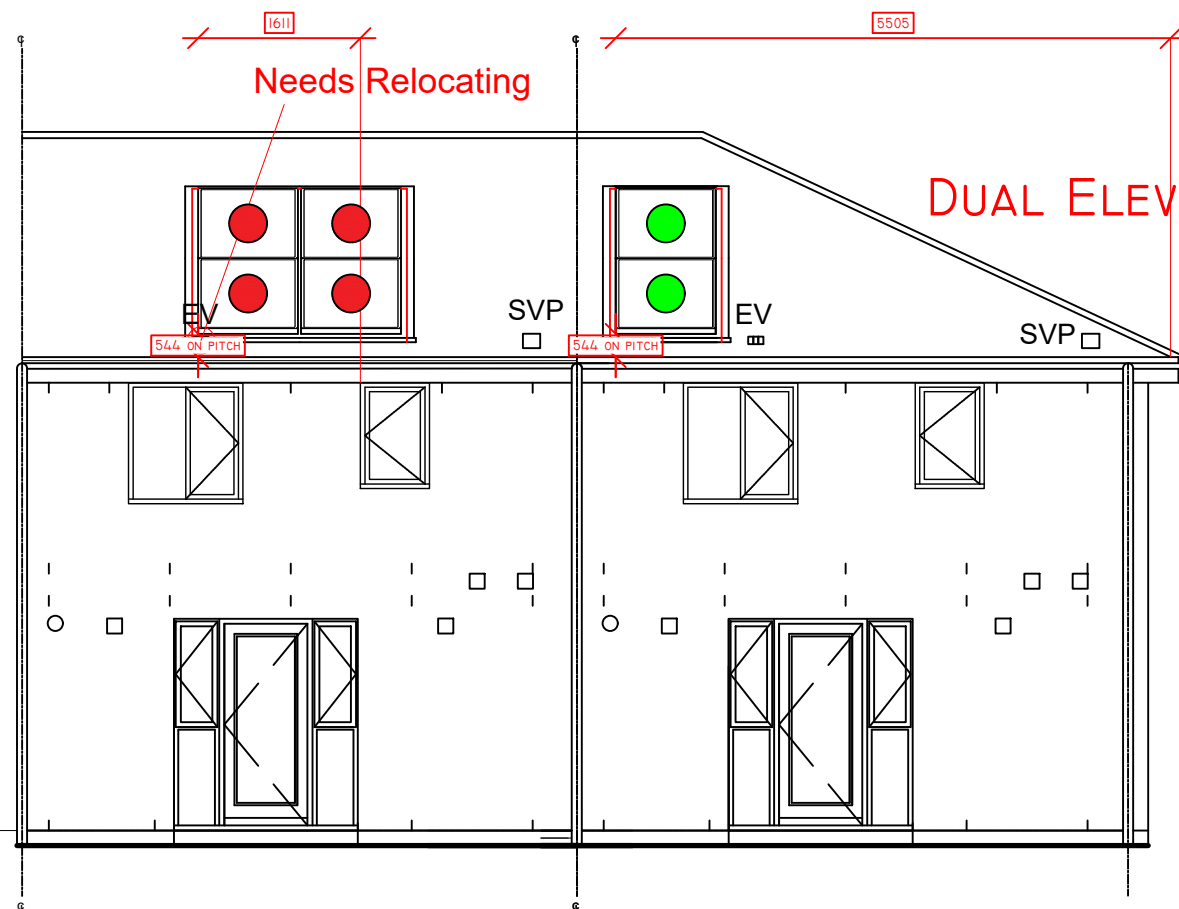

AS SHOWN -

MIRRORED -

REAR ELEVATION

MEASUREMENTS ARE APPROXIMATE

①

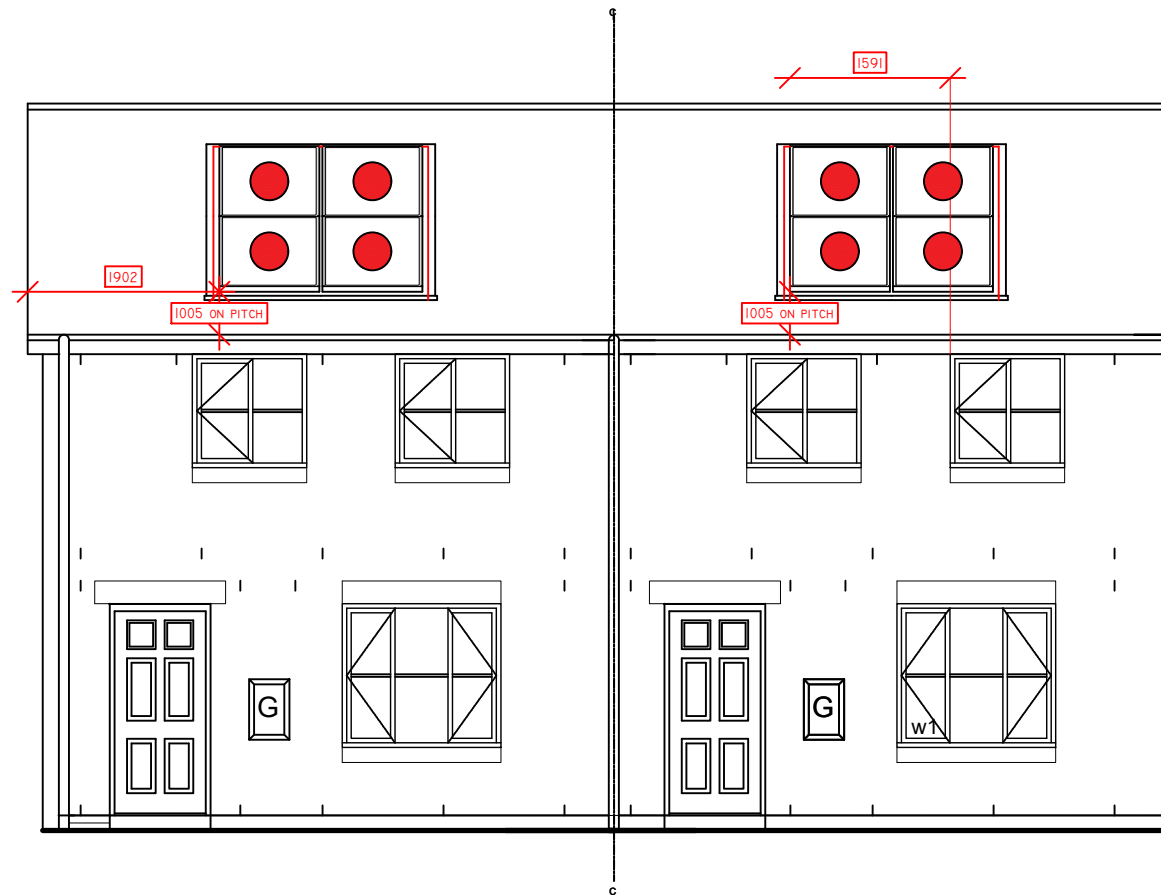

AS SHOWN -

MIRRORED -

FRONT ELEVATION

**SOLAR PV ARRANGEMENT
BARRATT HOMES
STAS AFFORDABLE 2020
ROSSDHU ET-MT GABLE
TBCPV**

STRING KEY

●	STRING 1	4	●	STRING 2	0
●	STRING 3	0	●	STRING 4	0
●	STRING 5	0	●	STRING 6	0
●	STRING 7	0	●	STRING 8	0

SYSTEM TYPE:	IN ROOF
SYSTEM NAME:	VIRIDIAN
POSITION:	PORTRAIT
SPLIT ELEVATION:	NO
PITCH:	25°
MODULE QUANTITY:	4

HOUSE TYPE:	ROSSDHU
DRAWN BY:	*3Z
DATE:	*4Z
CHECKED BY:	*5Z
DATE:	*6Z
SCALE @ A3:	1:75
REVISION:	*7Z

DISCLAIMER:
DESIGNS CREATED BY Eco2SOLAR ARE BASED ON INFORMATION PROVIDED TO US FROM THE CLIENT. Eco2SOLAR CANNOT ACCEPT LIABILITY FOR ERRORS RESULTING FROM INCORRECT INFORMATION SUPPLIED FROM THE CLIENT

②

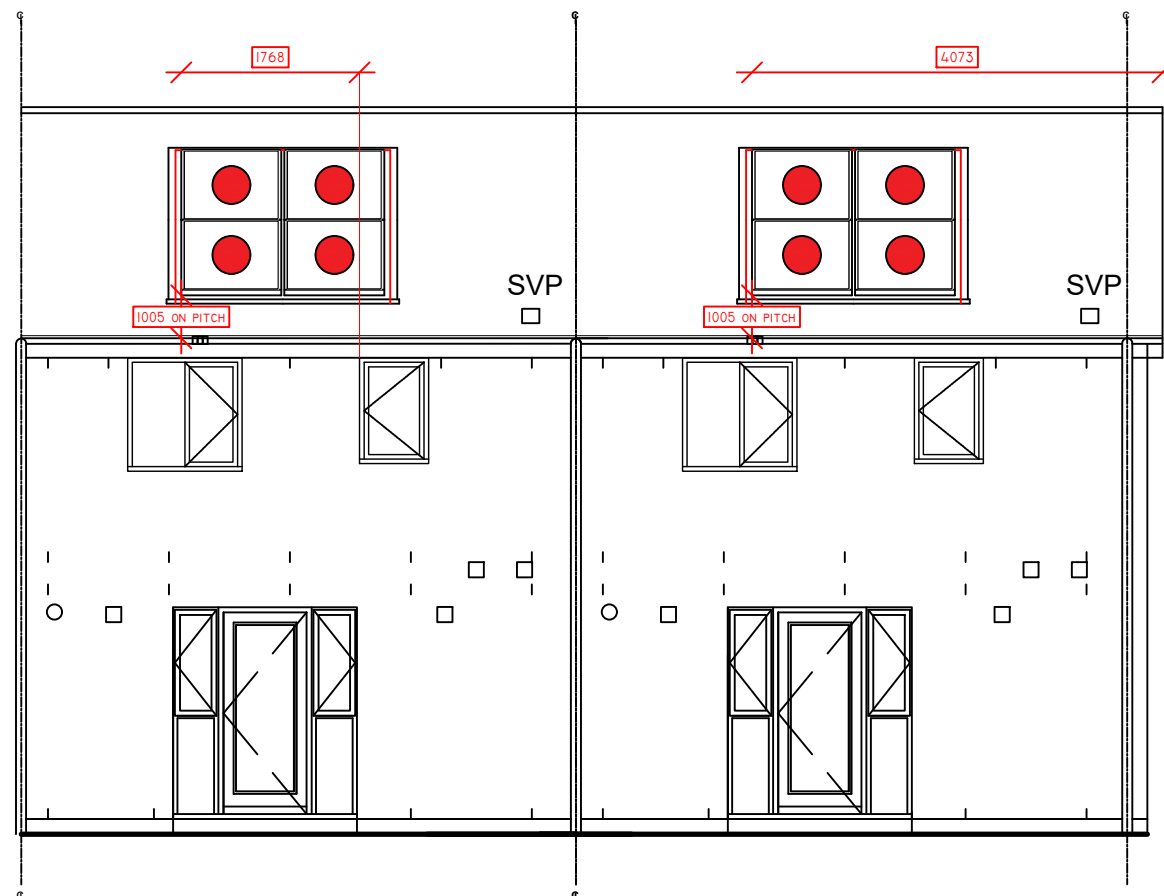

AS SHOWN -

MIRRORED -

REAR ELEVATION

eco₂solar
SUMMERFIELD HOUSE, ARTHUR DRIVE
HOO FARM INDUSTRIAL ESTATE
KIDDERMINSTER
WORCESTERSHIRE
DY11 7SL

MEASUREMENTS ARE APPROXIMATE

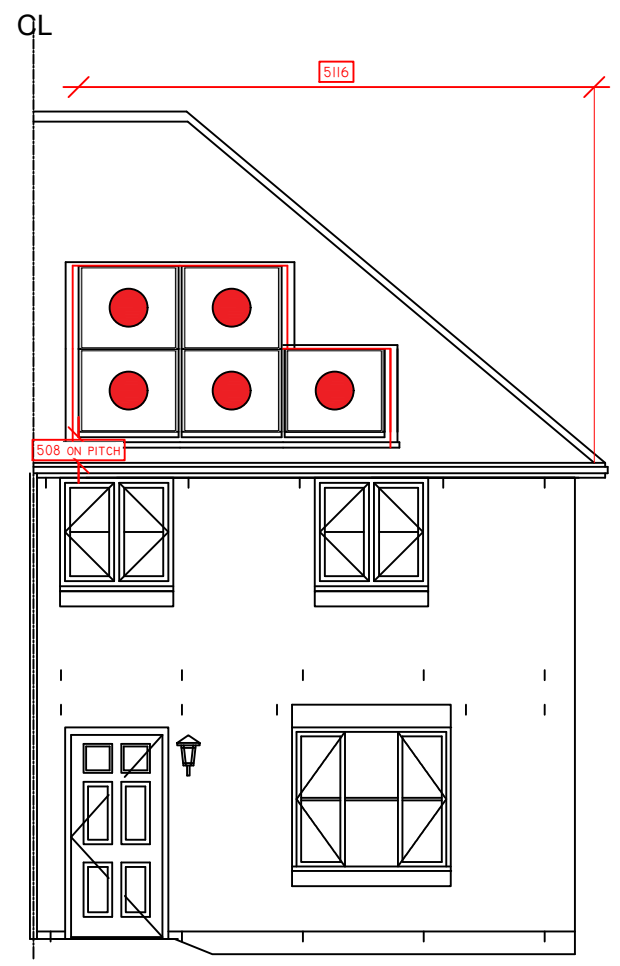

AS SHOWN -
MIRRORED -

FRONT ELEVATION

**SOLAR PV ARRANGEMENT
BARRATT HOMES
STAS AFFORDABLE 2020
SHANTRON ET
TBCPV**

STRING KEY

●	STRING 1	5	●	STRING 2	0
●	STRING 3	0	●	STRING 4	0
●	STRING 5	0	●	STRING 6	0
●	STRING 7	0	●	STRING 8	0

SYSTEM TYPE: IN ROOF
 SYSTEM NAME: VIRIDIAN
 POSITION: PORTRAIT
 SPLIT ELEVATION: NO
 PITCH: 30°
 MODULE QUANTITY: 5

HOUSE TYPE: SHANTRON
 DRAWN BY: *3Z
 DATE: *4Z
 CHECKED BY: *5Z
 DATE: *6Z
 SCALE @ A3: 1:75
 REVISION: *7Z

DISCLAIMER:
 DESIGNS CREATED BY Eco2SOLAR ARE BASED ON INFORMATION PROVIDED TO US FROM THE CLIENT. Eco2SOLAR CANNOT ACCEPT LIABILITY FOR ERRORS RESULTING FROM INCORRECT INFORMATION SUPPLIED FROM THE CLIENT

SUMMERFIELD HOUSE, ARTHUR DRIVE
 HOO FARM INDUSTRIAL ESTATE
 KIDDERMINSTER
 WORCESTERSHIRE
 DY11 7SL

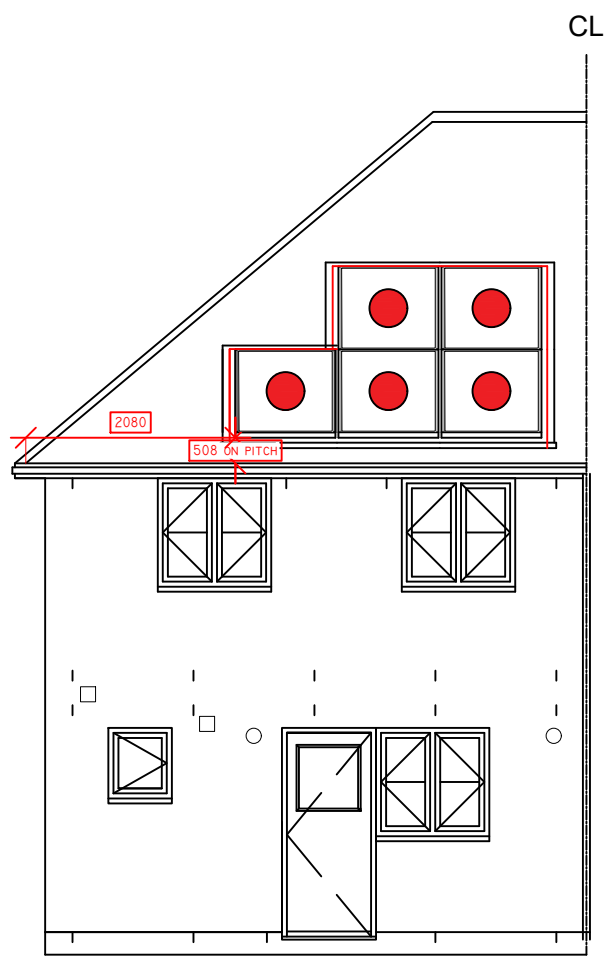

AS SHOWN -
MIRRORED -

REAR ELEVATION

MEASUREMENTS ARE APPROXIMATE

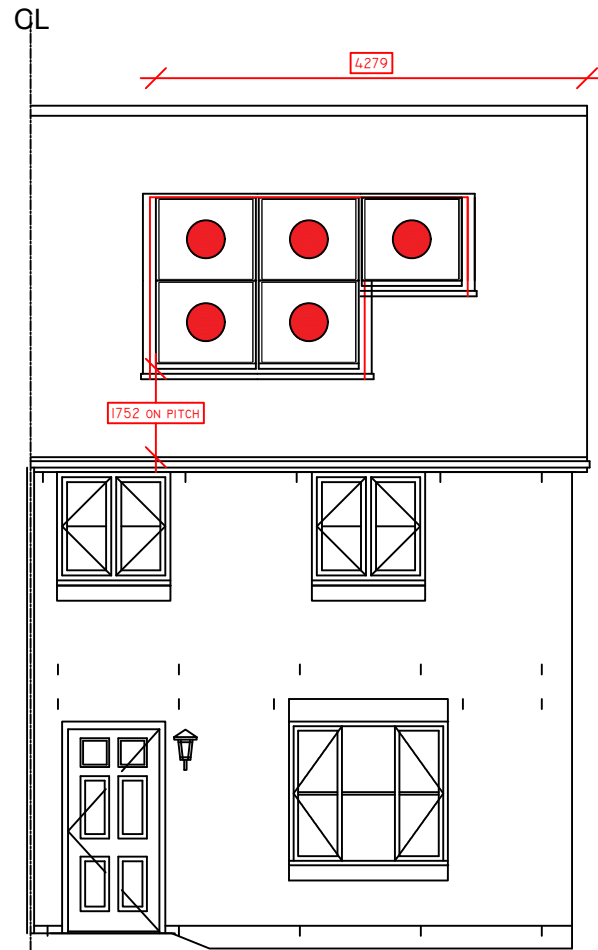

①

AS SHOWN -

MIRRORED -

FRONT ELEVATION

**SOLAR PV ARRANGEMENT
BARRATT HOMES
STAS AFFORDABLE 2020
SHANTRON ET GABLE
TBCPV**

STRING KEY

●	STRING 1	5	●	STRING 2	0
●	STRING 3	0	●	STRING 4	0
●	STRING 5	0	●	STRING 6	0
●	STRING 7	0	●	STRING 8	0

SYSTEM TYPE:	IN ROOF
SYSTEM NAME:	VIRIDIAN
POSITION:	PORTRAIT
SPLIT ELEVATION:	NO
PITCH:	30°
MODULE QUANTITY:	5

HOUSE TYPE:	SHANTRON
DRAWN BY:	*3Z
DATE:	*4Z
CHECKED BY:	*5Z
DATE:	*6Z
SCALE @ A3:	1:75
REVISION:	*7Z

DISCLAIMER:
DESIGNS CREATED BY ECO2SOLAR ARE BASED ON INFORMATION PROVIDED TO US FROM THE CLIENT. ECO2SOLAR CANNOT ACCEPT LIABILITY FOR ERRORS RESULTING FROM INCORRECT INFORMATION SUPPLIED FROM THE CLIENT

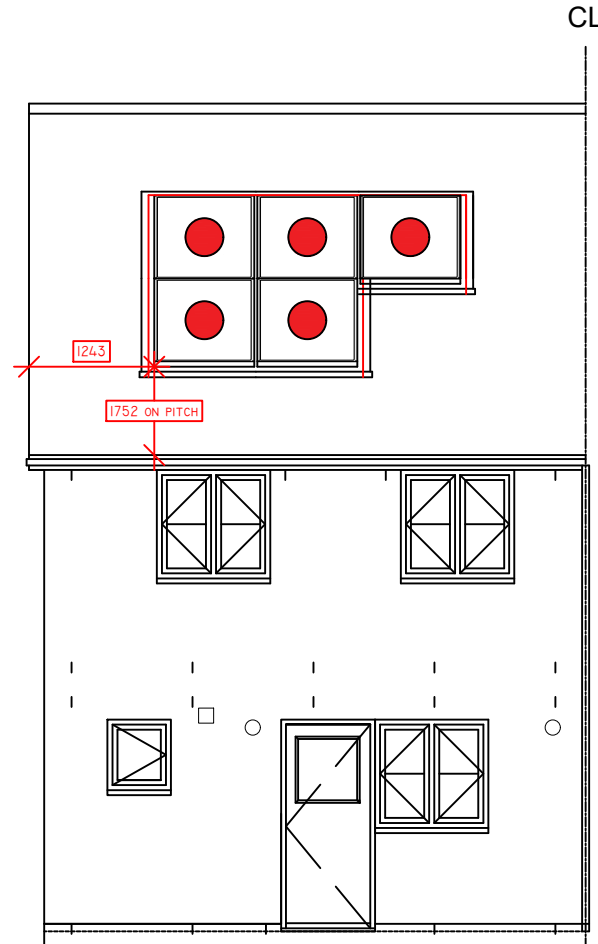

②

AS SHOWN -

MIRRORED -

REAR ELEVATION

SUMMERFIELD HOUSE, ARTHUR DRIVE
HOO FARM INDUSTRIAL ESTATE
KIDDERMINSTER
WORCESTERSHIRE
DY11 7SL

MEASUREMENTS ARE APPROXIMATE

1

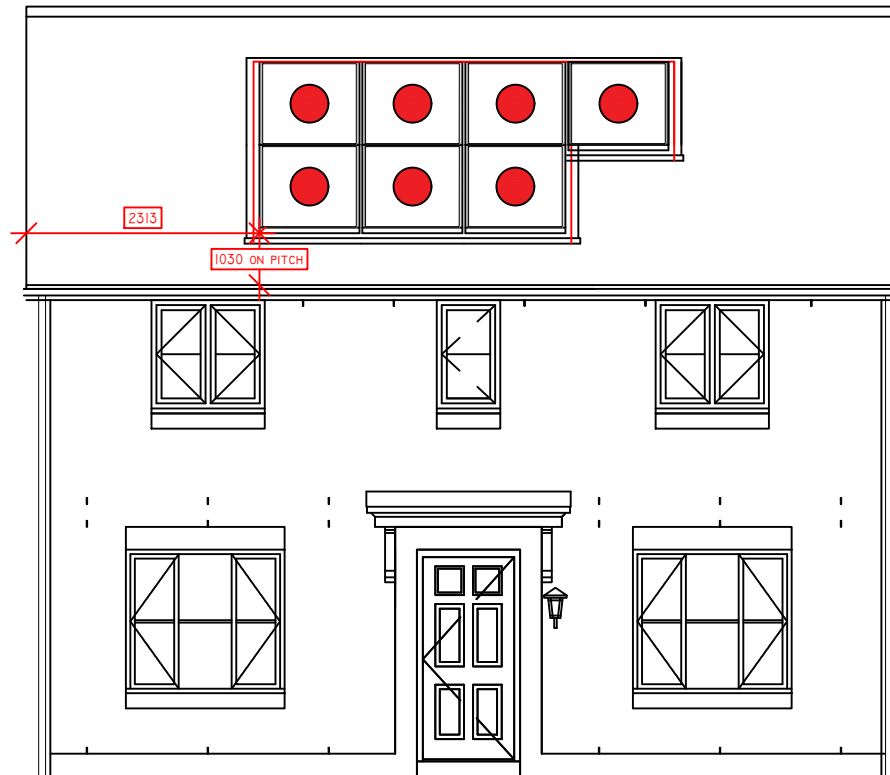

AS SHOWN -

MIRRORED -

FRONT ELEVATION

**SOLAR PV ARRANGEMENT
BARRATT HOMES
STAS AFFORDABLE 2020
SLOY
TBCPV**

STRING KEY

●	STRING 1	7	●	STRING 2	0
●	STRING 3	0	●	STRING 4	0
●	STRING 5	0	●	STRING 6	0
●	STRING 7	0	●	STRING 8	0

SYSTEM TYPE:	IN ROOF
SYSTEM NAME:	VIRIDIAN
POSITION:	PORTRAIT
SPLIT ELEVATION:	NO
PITCH:	30°
MODULE QUANTITY:	7

HOUSE TYPE:	SLOY
DRAWN BY:	*3Z
DATE:	*4Z
CHECKED BY:	*5Z
DATE:	*6Z
SCALE @ A3:	1:75
REVISION:	*7Z

DISCLAIMER:
DESIGNS CREATED BY Eco2SOLAR ARE BASED ON INFORMATION PROVIDED TO US FROM THE CLIENT. Eco2SOLAR CANNOT ACCEPT LIABILITY FOR ERRORS RESULTING FROM INCORRECT INFORMATION SUPPLIED FROM THE CLIENT

eco₂solar
SUMMERFIELD HOUSE, ARTHUR DRIVE
HOO FARM INDUSTRIAL ESTATE
KIDDERMINSTER
WORCESTERSHIRE
DY11 7SL

2

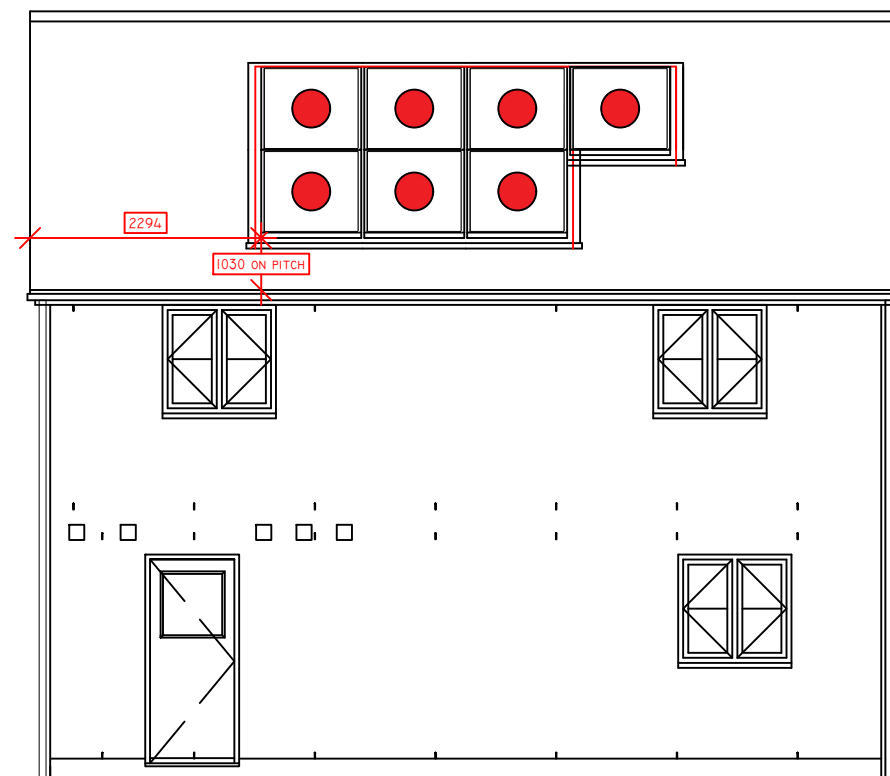

AS SHOWN -

MIRRORED -

REAR ELEVATION